

A01

POMPE FRENO Ø 17.46 - 11/16"
MASTER CYLINDERS Ø 17.46 - 11/16"

**A
01**

POMPA FRENO - MASTER CYLINDERS Ø 17.46 - 11/16"

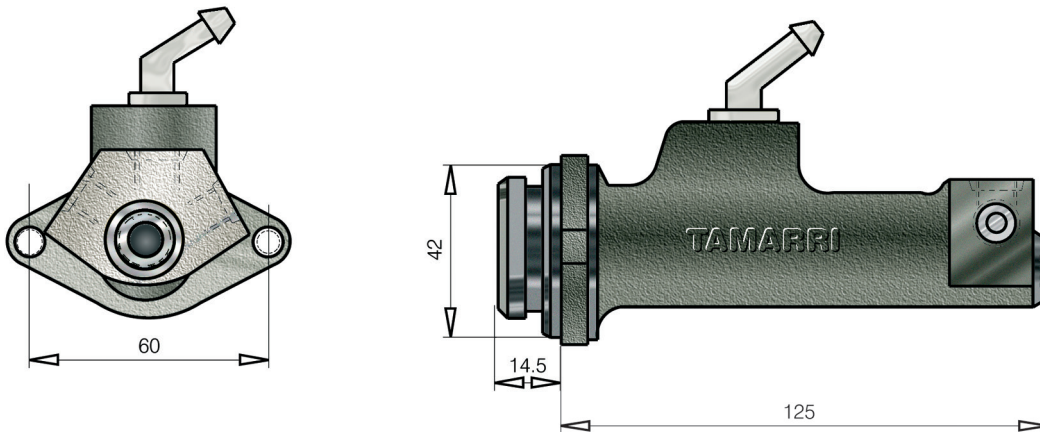

PF206/B Olio freni DOT3-4 - Brake oil DOT3-4

BT

M1 10x1 	M2 10x1
M3 10x1 	M4 10x1
Uscita Olio - Oil exit	

POMPA FRENO - MASTER CYLINDERS Ø 17.46 - 11/16"

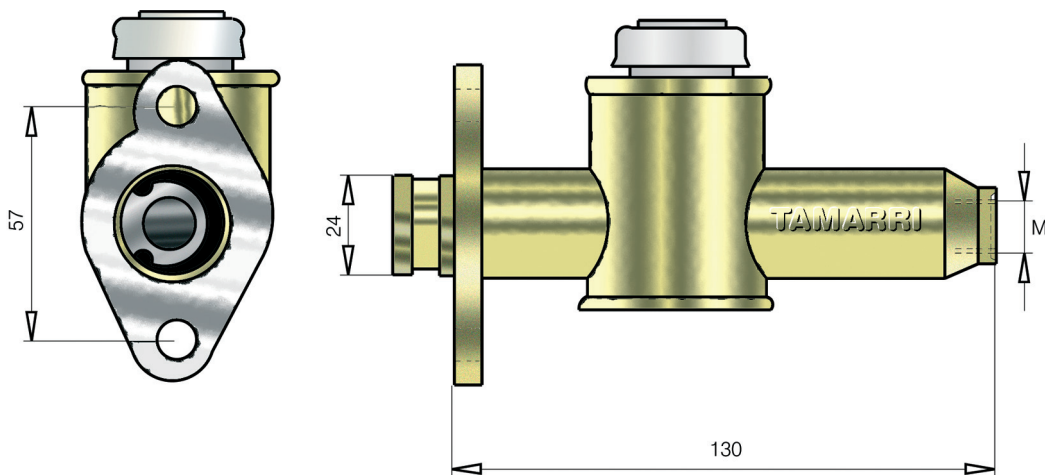

PF236 Olio freni DOT3-4 - Brake oil DOT3-4

Lansing B.

M1 12x1 	M2
M3	M4
Uscita Olio - Oil exit	

POMPA FRENO - MASTER CYLINDERS Ø 17.46 - 11/16"

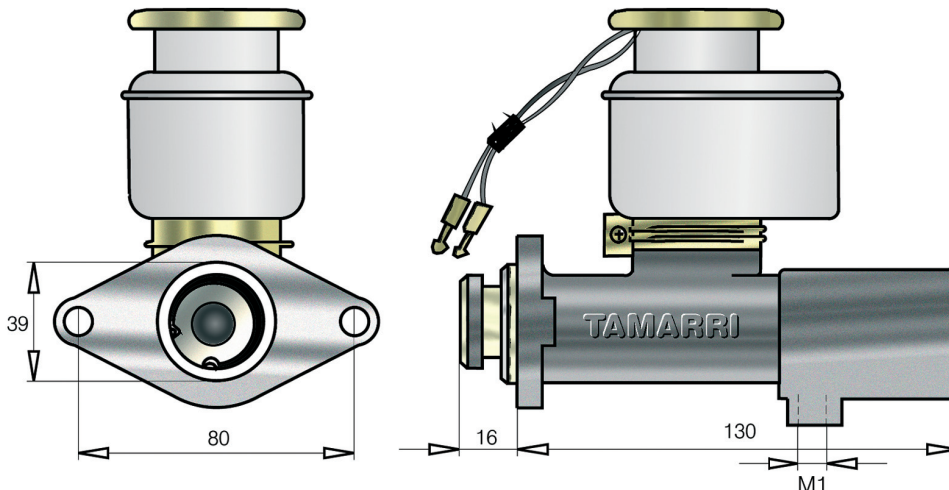

PF319 Olio freni DOT3-4 - Brake oil DOT3-4

Nissan - Caterpillar - Hyster

M1 10x1 	M2 10x1
M3	M4
Uscita Olio - Oil exit	



I nostri ricambi non sono originali ma con essi perfettamente intercambiabili
 Our spare parts are not original but with them perfectly interchangeable



POMPE FRENO Ø 17.46 - 11/16"
MASTER CYLINDERS Ø 17.46 - 11/16"

**A
01**

POMPA FRENO - MASTER CYLINDERS Ø 17.46 - 11/16"

PF329 Olio freni DOT3-4 - Brake oil DOT3-4 Nissan

M1	M2
M3	M4
Uscita Olio - Oil exit	

POMPA FRENO - MASTER CYLINDERS Ø 17.46 - 11/16"

PF045 Olio freni DOT3-4 - Brake oil DOT3-4 Halla

M1	M2
M3	M4
Uscita Olio - Oil exit	

POMPA FRENO - MASTER CYLINDERS Ø 17.46 - 11/16"

PF238 Olio freni DOT3-4 - Brake oil DOT3-4 Coventry - Climax

M1	M2
M3	M4
Uscita Olio - Oil exit	



I nostri ricambi non sono originali ma con essi perfettamente intercambiabili
 Our spare parts are not original but with them perfectly interchangeable

A01

POMPE FRENO Ø 17.46 - 11/16"
MASTER CYLINDERS Ø 17.46 - 11/16"

**A
01**

POMPA FRENO - MASTER CYLINDERS Ø 17.46 - 11/16"

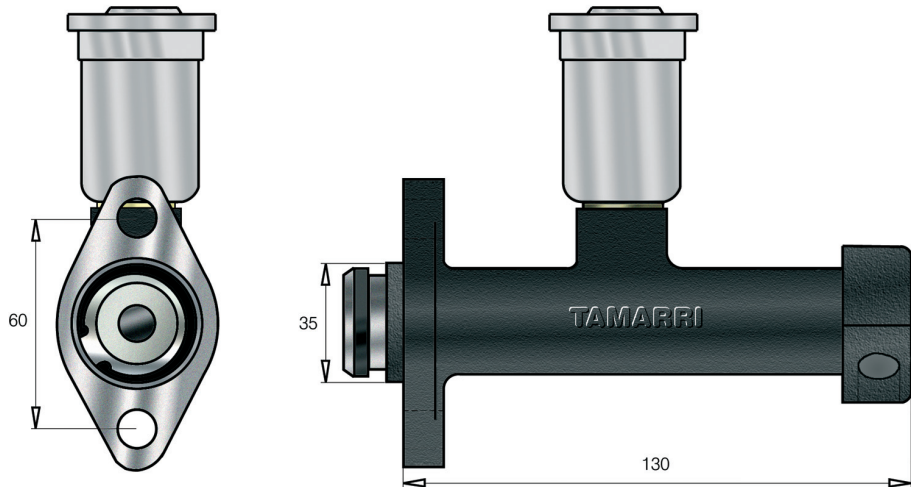

PF262 Olio freni DOT3-4 - Brake oil DOT3-4

Halla

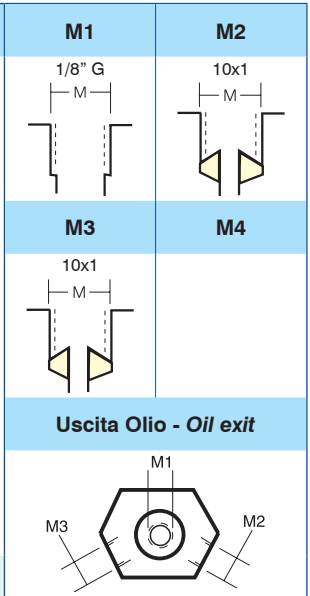

POMPA FRENO - MASTER CYLINDERS Ø 17.46 - 11/16"

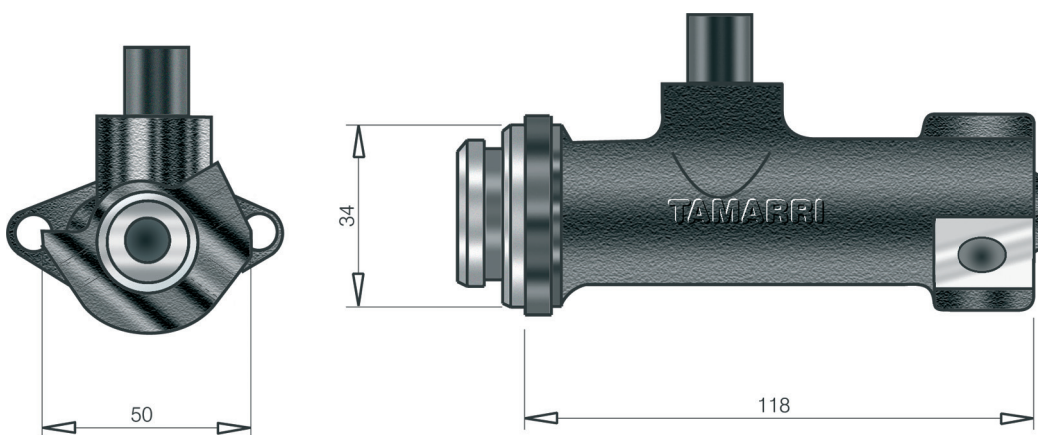

PF324 Olio freni DOT3-4 - Brake oil DOT3-4

Jungheinrich

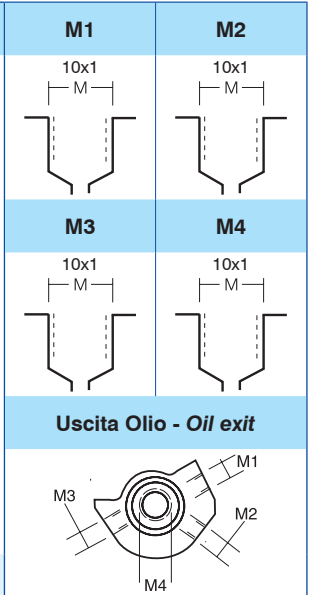

POMPA FRENO - MASTER CYLINDERS Ø 17.46 - 11/16"

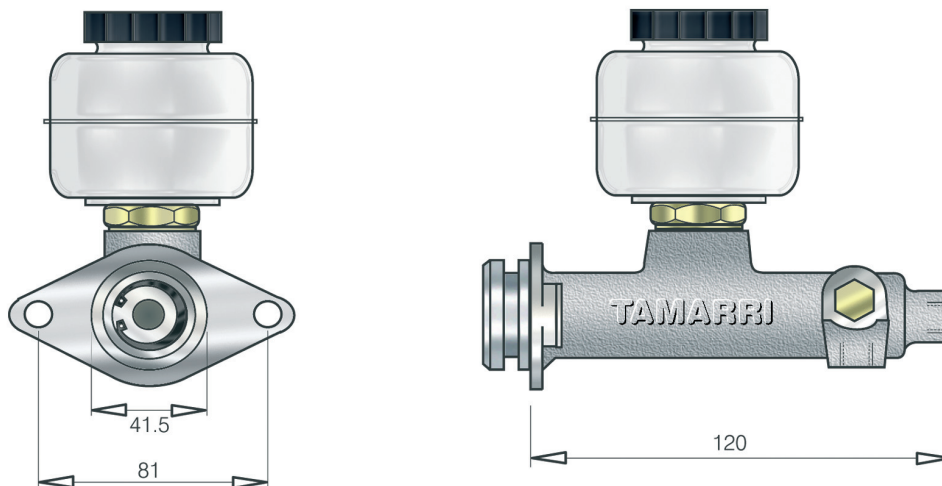

PF334 Olio freni DOT3-4 - Brake oil DOT3-4

International

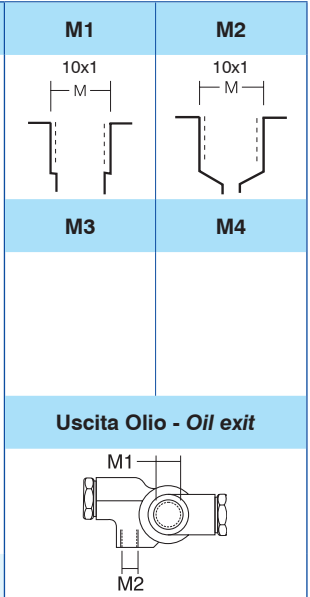

I nostri ricambi non sono originali ma con essi perfettamente intercambiabili
 Our spare parts are not original but with them perfectly interchangeable



POMPE FRENO Ø 17.46 - 11/16"
MASTER CYLINDERS Ø 17.46 - 11/16"

**A
01**

POMPA FRENO - MASTER CYLINDERS Ø 17.46 - 11/16"

M1	M2
M3	M4
Uscita Olio - Oil exit	

PF345 Olio freni DOT3-4 - Brake oil DOT3-4 Crown

POMPA FRENO - MASTER CYLINDERS Ø 17.46 - 11/16"

M1	M2
M3	M4
Uscita Olio - Oil exit	

PF362 Olio freni DOT3-4 - Brake oil DOT3-4 Nissan

POMPA FRENO - MASTER CYLINDERS Ø 17.46 - 11/16"

M1	M2
M3	M4
Uscita Olio - Oil exit	

PF380 Olio freni DOT3-4 - Brake oil DOT3-4 Nissan



I nostri ricambi non sono originali ma con essi perfettamente intercambiabili
 Our spare parts are not original but with them perfectly interchangeable



POMPE FRENO Ø 17.46 - 11/16"
MASTER CYLINDERS Ø 17.46 - 11/16"

**A
01**

POMPA FRENO - MASTER CYLINDERS Ø 17.46 - 11/16"		M1	M2
		Uscita Olio - Oil exit	
PF386	Olio freni DOT3-4 - Brake oil DOT3-4	Nissan	

POMPA FRENO - MASTER CYLINDERS Ø 17.46 - 11/16"		M1	M2
		Uscita Olio - Oil exit	
PF388	Olio freni DOT3-4 - Brake oil DOT3-4	Daewoo	

POMPA FRENO - MASTER CYLINDERS Ø 17.46 - 11/16"		M1	M2
		Uscita Olio - Oil exit	
PF397	Olio freni DOT3-4 - Brake oil DOT3-4	Landini	



I nostri ricambi non sono originali ma con essi perfettamente intercambiabili
 Our spare parts are not original but with them perfectly interchangeable



POMPE FRENO Ø 17.46 - 11/16"
MASTER CYLINDERS Ø 17.46 - 11/16"

**A
01**

POMPA FRENO - WMASTER CYLINDERS Ø 17.46 - 11/16"

M1	M2
M3	M4
Uscita Olio - Oil exit	

PF403 Olio freni DOT3-4 - Brake oil DOT3-4

POMPA FRENO - MASTER CYLINDERS Ø 17.46 - 11/16"

M1	M2
M3	M4
Uscita Olio - Oil exit	

PF404 Olio freni DOT3-4 - Brake oil DOT3-4

POMPA FRENO - MASTER CYLINDERS Ø 17.46 - 11/16"

M1	M2
M3	M4
Uscita Olio - Oil exit	

PF428 Olio freni DOT3-4 - Brake oil DOT3-4 Deutz



I nostri ricambi non sono originali ma con essi perfettamente intercambiabili
 Our spare parts are not original but with them perfectly interchangeable



POMPE FRENO Ø 17.46 - 11/16"
MASTER CYLINDERS Ø 17.46 - 11/16"

**A
01**

POMPA FRENO - MASTER CYLINDERS Ø 17.46 - 11/16"		M1	M2
		Uscita Olio - Oil exit	
PF452	Olio freni DOT3-4 - Brake oil DOT3-4	OMG	

POMPA FRENO - MASTER CYLINDERS Ø 17.46 - 11/16" TANDEM		M1	M2
		Uscita Olio - Oil exit	
PF005	Olio freni DOT3-4 - Brake oil DOT3-4		

POMPA FRENO - MASTER CYLINDERS Ø 17.46 - 11/16"		M1	M2
		Uscita Olio - Oil exit	
TA38150	Olio minerale - Mineral oil	New Holland Ford	

