



POMPE FRENO Ø 19.05 - 3/4"
MASTER CYLINDERS Ø 19.05 - 3/4"

**A
01**

POMPA FRENO - MASTER CYLINDERS Ø 19,05 - 3/4"		M1	M2
		M3	M4
PF101/A Fori passanti non filettati - <i>Passer-by holes not threaded</i>		Allis - Caterpillar - Clark - Hyster	
		Uscita Olio - Oil exit	

POMPA FRENO - MASTER CYLINDERS Ø 19,05 - 3/4"		M1	M2
		M3	M4
PF101/C Fori non passanti filettati - <i>Threaded holes not passer-by</i>		Clark	
		Uscita Olio - Oil exit	

POMPA FRENO - MASTER CYLINDERS Ø 19,05 - 3/4"		M1	M2
		M3	M4
PF101/G Fori passanti filettati - <i>Threaded through holes</i>		Caterpillar - Hyster	
		Uscita Olio - Oil exit	





POMPE FRENO Ø 19.05 - 3/4"
MASTER CYLINDERS Ø 19.05 - 3/4"

**A
01**

POMPA FRENO - MASTER CYLINDERS Ø 19,05 - 3/4"		M1	M2
		M3	M4
		Uscita Olio - Oil exit	
PF302	Olío freni DOT3-4 - Brake oil DOT3-4	OM - Pimespo - Peschiera - Goldoni	
PF302M	Olío minerale - Mineral oil	Goldoni	

POMPA FRENO - MASTER CYLINDERS Ø 19,05 - 3/4"		M1	M2
		M3	M4
		Uscita Olio - Oil exit	
PF475	Olío freni DOT3-4 - Brake oil DOT3-4	Goldoni	

POMPA FRENO - MASTER CYLINDERS Ø 19,05 - 3/4"		M1	M2
		M3	M4
		Uscita Olio - Oil exit	
PF306	Olío freni DOT3-4 - Brake oil DOT3-4	OM - Pimespo	
PF306M	Olío minerale - Mineral oil	Pieralisi	



I nostri ricambi non sono originali ma con essi perfettamente intercambiabili
 Our spare parts are not original but with them perfectly interchangeable



POMPE FRENO Ø 19.05 - 3/4"
MASTER CYLINDERS Ø 19.05 - 3/4"

**A
01**

POMPA FRENO - MASTER CYLINDERS Ø 19,05 - 3/4"

M1	M2
M3	M4
Uscita Olio - Oil exit	

PF306A Fusione alluminio - *Aluminium body* OM - Pimespo

POMPA FRENO - MASTER CYLINDERS Ø 19,05 - 3/4"

M1	M2
M3	M4
Uscita Olio - Oil exit	

PF209/A Fusione alluminio - *Aluminium body*

POMPA FRENO - MASTER CYLINDERS Ø 19,05 - 3/4"

M1	M2
M3	M4
Uscita Olio - Oil exit	

PF202 Olio freni DOT3-4 - *Brake oil DOT3-4* Cesab





POMPE FRENO Ø 19.05 - 3/4"
MASTER CYLINDERS Ø 19.05 - 3/4"

**A
01**

POMPA FRENO - MASTER CYLINDERS Ø 19,05 - 3/4"

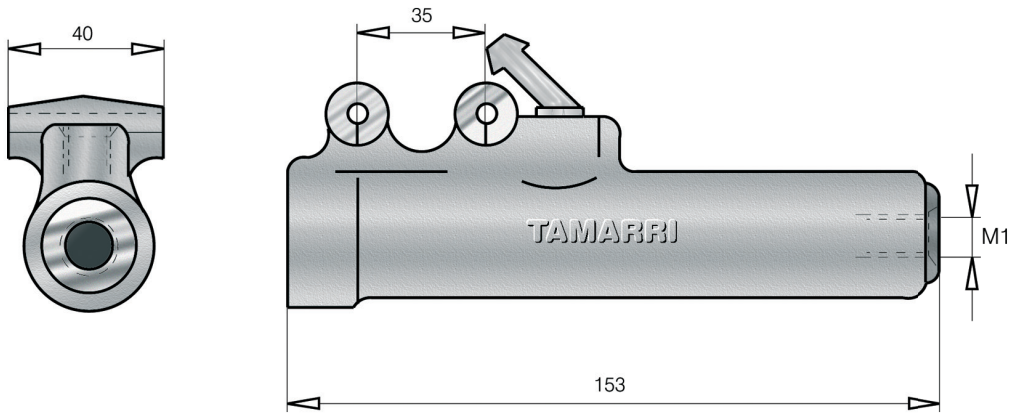

M1	M2
12x1 M	
M3	M4
Uscita Olio - Oil exit	

PF222 Olio freni DOT3-4 - Brake oil DOT3-4 Clark

POMPA FRENO - MASTER CYLINDERS Ø 19,05 - 3/4"

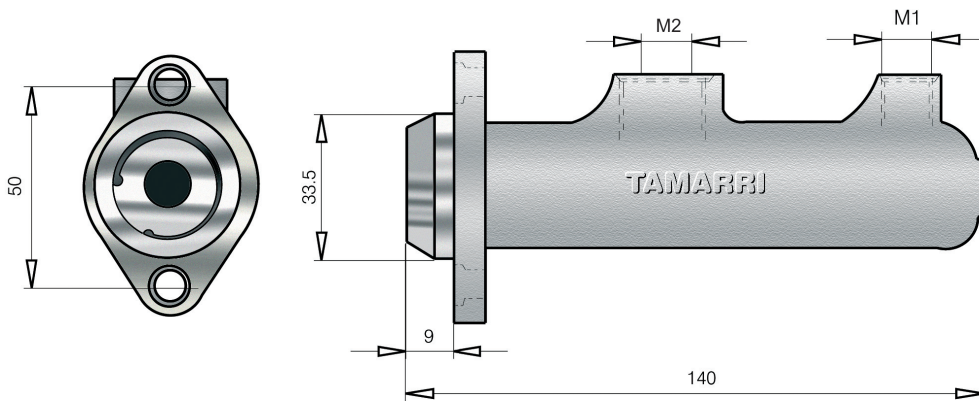

M1	M2
3/8" 24 fil. M	16x1,5 M
M3	M4
Uscita Olio - Oil exit	

PF208 Olio freni DOT3-4 - Brake oil DOT3-4 Matral

POMPA FRENO - MASTER CYLINDERS Ø 19,05 - 3/4"

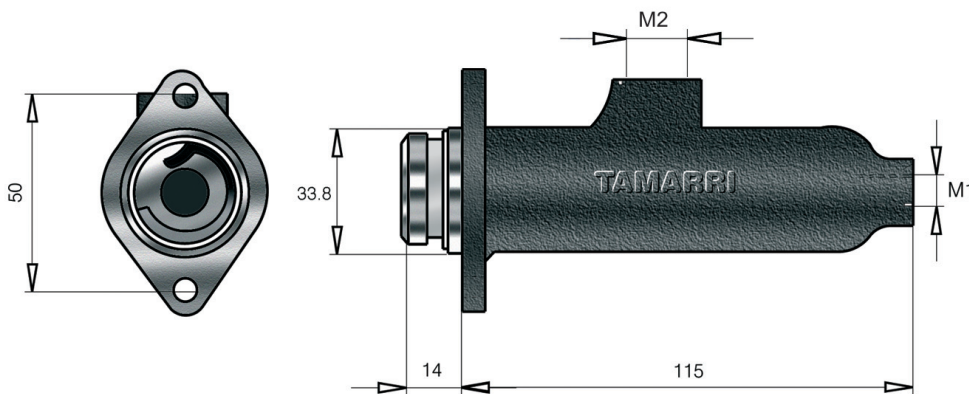

M1	M2
7/16" 20 fil. M	16x1,5 M
M3	M4
Uscita Olio - Oil exit	

PF223 Olio freni DOT3-4 - Brake oil DOT3-4 Fenwick





POMPE FRENO Ø 19.05 - 3/4"
MASTER CYLINDERS Ø 19.05 - 3/4"

**A
01**

POMPA FRENO - MASTER CYLINDERS Ø 19,05 - 3/4"

M1	M2
3/8" 24 fil. M	
M3	M4
Uscita Olio - Oil exit	

PF212 Olio freni DOT3-4 - Brake oil DOT3-4 Lansing B. - Linde

POMPA FRENO - MASTER CYLINDERS Ø 19,05 - 3/4"

M1	M2
3/8" 24 fil. M	
M3	M4
Uscita Olio - Oil exit	

PF215 Olio freni DOT3-4 - Brake oil DOT3-4 Lansing B.

POMPA FRENO - MASTER CYLINDERS Ø 19,05 - 3/4"

M1	M2
3/8" 24 fil. M	
M3	M4
Uscita Olio - Oil exit	

PF213 Olio freni DOT3-4 - Brake oil DOT3-4 Lansing B. - Saxby





POMPE FRENO Ø 19.05 - 3/4"
MASTER CYLINDERS Ø 19.05 - 3/4"

**A
01**

POMPA FRENO - MASTER CYLINDERS Ø 19,05 - 3/4"

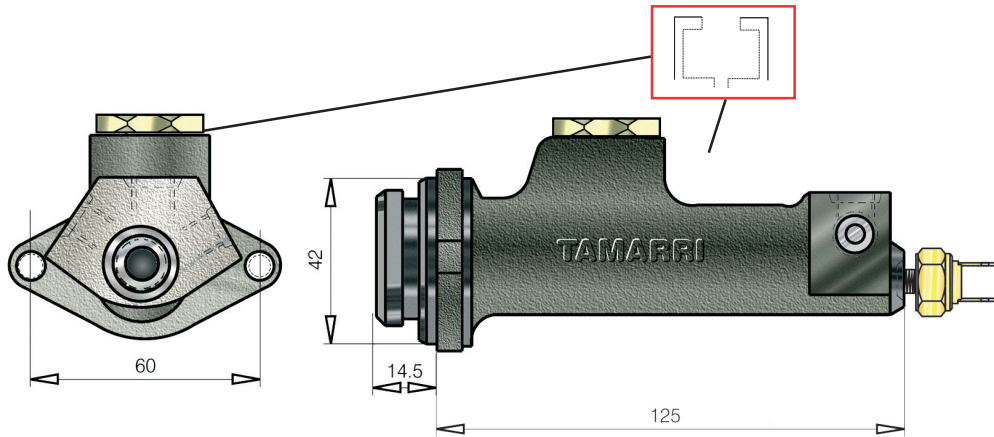

M1	M2
10x1 M	10x1 M
M3	M4
10x1 M	10x1 M
Uscita Olio - Oil exit	

PF412 Olio freni DOT3-4 - Brake oil DOT3-4 Jungheinrich

POMPA FRENO - MASTER CYLINDERS Ø 19,05 - 3/4"

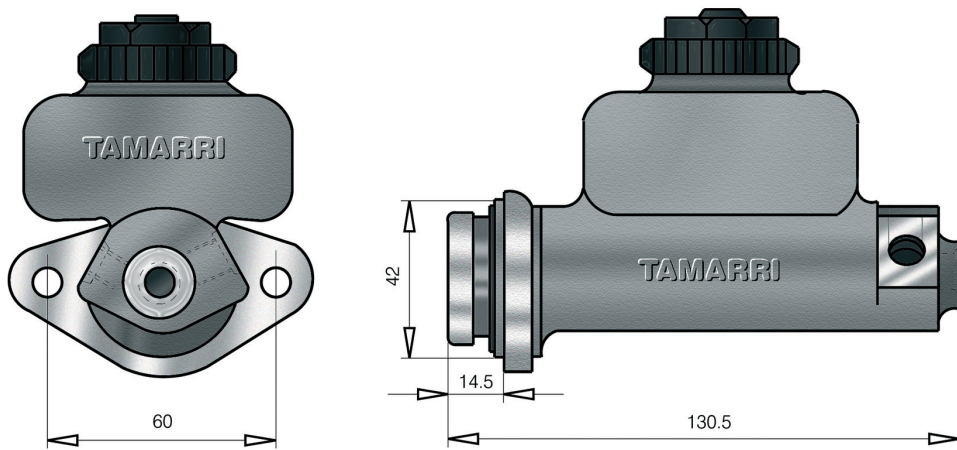

M1	M2
10x1 M	10x1 M
M3	M4
10x1 M	
Uscita Olio - Oil exit	

PF200 Olio freni DOT3-4 - Brake oil DOT3-4 Sibicar - Still - Lancer - Jungheinrich

POMPA FRENO - MASTER CYLINDERS Ø 19,05 - 3/4"

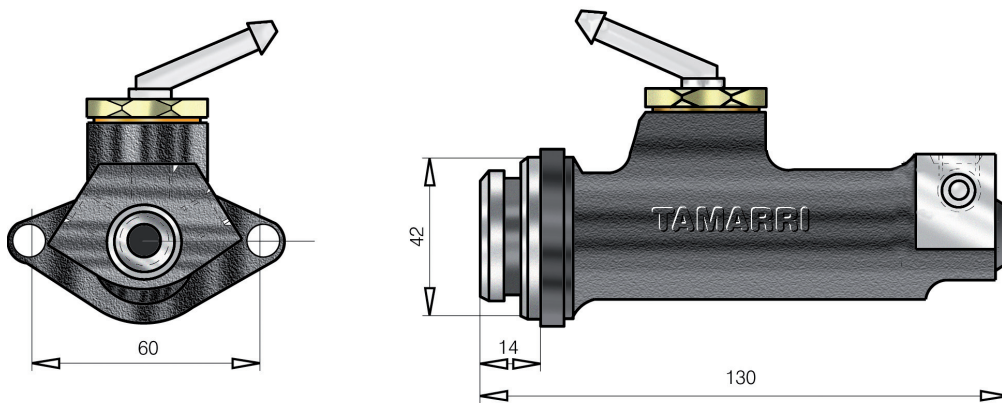

M1	M2
10x1 M	10x1 M
M3	M4
10x1 M	10x1 M
Uscita Olio - Oil exit	

PF206/A Olio freni DOT3-4 - Brake oil DOT3-4 Still - Linde



I nostri ricambi non sono originali ma con essi perfettamente intercambiabili
 Our spare parts are not original but with them perfectly interchangeable



POMPE FRENO Ø 19.05 - 3/4"
MASTER CYLINDERS Ø 19.05 - 3/4"

**A
01**

POMPA FRENO - MASTER CYLINDERS Ø 19,05 - 3/4"

M1	M2
10x1 M	10x1 M
M3	M4
10x1 M	10x1 M
Uscita Olio - Oil exit	

PF205/A Olio freni DOT3-4 - Brake oil DOT3-4 Still

POMPA FRENO - MASTER CYLINDERS Ø 19,05 - 3/4"

M1	M2
10x1 M	10x1 M
M3	M4
10x1 M	10x1 M
Uscita Olio - Oil exit	

PF409 Olio freni DOT3-4 - Brake oil DOT3-4 *Con sensore livello olio with oil level detector* Jungheinrich

POMPA FRENO - MASTER CYLINDERS Ø 19,05 - 3/4"

M1	M2
10x1 M	10x1 M
M3	M4
1/8" G M	
Uscita Olio - Oil exit	

PF078 Olio freni DOT3-4 - Brake oil DOT3-4 Mitsubishi



I nostri ricambi non sono originali ma con essi perfettamente intercambiabili
 Our spare parts are not original but with them perfectly interchangeable

A01

POMPE FRENO Ø 19.05 - 3/4"
MASTER CYLINDERS Ø 19.05 - 3/4"

A
01

POMPA FRENO - MASTER CYLINDERS Ø 19,05 - 3/4"		M1	M2
<p>PF286 Olio freni DOT3-4 - Brake oil DOT3-4 <i>Con sensore livello olio with oil level detector</i> Mitsubishi</p>		<p>Uscita Olio - Oil exit</p>	

POMPA FRENO - MASTER CYLINDERS Ø 19,05 - 3/4"		M1	M2
<p>PF218 Olio freni DOT3-4 - Brake oil DOT3-4 Mitsubishi</p>		<p>Uscita Olio - Oil exit</p>	

POMPA FRENO - MASTER CYLINDERS Ø 19,05 - 3/4"		M1	M2
<p>PF221 Olio freni DOT3-4 - Brake oil DOT3-4 Toyota - Komatsu</p>		<p>Uscita Olio - Oil exit</p>	



I nostri ricambi non sono originali ma con essi perfettamente intercambiabili
 Our spare parts are not original but with them perfectly interchangeable



POMPE FRENO Ø 19.05 - 3/4"
MASTER CYLINDERS Ø 19.05 - 3/4"

**A
01**

POMPA FRENO - MASTER CYLINDERS Ø 19,05 - 3/4"		M1	M2
		M3	M4
		Uscita Olio - Oil exit	
PF077	Olío freni DOT3-4 - Brake oil DOT3-4	Toyota	

POMPA FRENO - MASTER CYLINDERS Ø 19,05 - 3/4"		M1	M2
		M3	M4
		Uscita Olio - Oil exit	
PF225	Olío freni DOT3-4 - Brake oil DOT3-4	Toyota	

POMPA FRENO - MASTER CYLINDERS Ø 19,05 - 3/4"		M1	M2
		M3	M4
		Uscita Olio - Oil exit	
PF225A	Olío freni DOT3-4 - Brake oil DOT3-4 Con kit serbatoio With oil tank kit	Toyota	



I nostri ricambi non sono originali ma con essi perfettamente intercambiabili
 Our spare parts are not original but with them perfectly interchangeable



POMPE FRENO Ø 19.05 - 3/4"
MASTER CYLINDERS Ø 19.05 - 3/4"

**A
01**

POMPA FRENO - MASTER CYLINDERS Ø 19,05 - 3/4"		M1	M2
		M3	M4
Uscita Olio - Oil exit			
PF225B	Olio freni DOT3-4 - Brake oil DOT3-4		Toyota

POMPA FRENO - MASTER CYLINDERS Ø 19,05 - 3/4"		M1	M2
		M3	M4
Uscita Olio - Oil exit			
PF316	Olio freni DOT3-4 - Brake oil DOT3-4		Fimsa - F.Lli Dieci

POMPA FRENO - MASTER CYLINDERS Ø 19,05 - 3/4"		M1	M2
		M3	M4
Uscita Olio - Oil exit			
PF310	Olio freni DOT3-4 - Brake oil DOT3-4		Icem - Robustus
PF310M	Olio minerale - Mineral oil		F.lli Dieci





POMPE FRENO Ø 19.05 - 3/4"
MASTER CYLINDERS Ø 19.05 - 3/4"

**A
01**

POMPA FRENO - MASTER CYLINDERS Ø 19,05 - 3/4"		M1	M2
		M3	M4
<p>PF216/A Olio freni DOT3-4 - Brake oil DOT3-4 Nissan</p>		<p>Uscita Olio - Oil exit</p>	

POMPA FRENO - MASTER CYLINDERS Ø 19,05 - 3/4"		M1	M2
		M3	M4
<p>PF232 Olio freni DOT3-4 - Brake oil DOT3-4 TCM</p>		<p>Uscita Olio - Oil exit</p>	

POMPA FRENO - MASTER CYLINDERS Ø 19,05 - 3/4"		M1	M2
		M3	M4
<p>PF315 Olio freni DOT3-4 - Brake oil DOT3-4 Lansing B. - Jungheinrich</p>		<p>Uscita Olio - Oil exit</p>	



I nostri ricambi non sono originali ma con essi perfettamente intercambiabili
 Our spare parts are not original but with them perfectly interchangeable



POMPE FRENO Ø 19.05 - 3/4"
MASTER CYLINDERS Ø 19.05 - 3/4"

**A
01**

POMPA FRENO - MASTER CYLINDERS Ø 19,05 - 3/4"		M1	M2
<p>PF231/A Olio freni DOT3-4 - Brake oil DOT3-4 NYK</p>		<p>Uscita Olio - Oil exit</p>	

POMPA FRENO - MASTER CYLINDERS Ø 19,05 - 3/4"		M1	M2
<p>PF466 Olio freni DOT3-4 - Brake oil DOT3-4 HANGCHA</p>		<p>Uscita Olio - Oil exit</p>	

POMPA FRENO - MASTER CYLINDERS Ø 19,05 - 3/4"		M1	M2
<p>PF467 Olio freni DOT3-4 - Brake oil DOT3-4 HANGCHA</p>		<p>Uscita Olio - Oil exit</p>	



I nostri ricambi non sono originali ma con essi perfettamente intercambiabili
 Our spare parts are not original but with them perfectly interchangeable



POMPE FRENO Ø 19.05 - 3/4"
MASTER CYLINDERS Ø 19.05 - 3/4"

**A
01**

POMPA FRENO - MASTER CYLINDERS Ø 19,05 - 3/4"		M1	M2
		M3	M4
		Uscita Olio - Oil exit	
PF023	Olío freni DOT3-4 - Brake oil DOT3-4		OM

POMPA FRENO - MASTER CYLINDERS Ø 19,05 - 3/4"		M1	M2
		M3	M4
		Uscita Olio - Oil exit	
PF299M	Olío minerale - Mineral oil		JCB

POMPA FRENO - MASTER CYLINDERS Ø 19,05 - 3/4"		M1	M2
		M3	M4
		Uscita Olio - Oil exit	
PF230/D	Olío freni DOT3-4 - Brake oil DOT3-4		Clark - Hyster



I nostri ricambi non sono originali ma con essi perfettamente intercambiabili
 Our spare parts are not original but with them perfectly interchangeable



POMPE FRENO Ø 19.05 - 3/4"
MASTER CYLINDERS Ø 19.05 - 3/4"

**A
01**

POMPA FRENO - MASTER CYLINDERS Ø 19,05 - 3/4"		M1	M2
		M3	M4
		Uscita Olio - Oil exit	
PF247	Olio freni DOT3-4 - Brake oil DOT3-4	Yale - Hyster - Caterpillar	

POMPA FRENO - MASTER CYLINDERS Ø 19,05 - 3/4"		M1	M2
		M3	M4
		Uscita Olio - Oil exit	
PF244	Olio freni DOT3-4 - Brake oil DOT3-4	Yale - Hyster - Caterpillar	

POMPA FRENO - MASTER CYLINDERS Ø 19,05 - 3/4"		M1	M2
		M3	M4
		Uscita Olio - Oil exit	
PF245	Olio freni DOT3-4 - Brake oil DOT3-4	TCM	



I nostri ricambi non sono originali ma con essi perfettamente intercambiabili
 Our spare parts are not original but with them perfectly interchangeable



POMPE FRENO Ø 19.05 - 3/4"
MASTER CYLINDERS Ø 19.05 - 3/4"

**A
01**

POMPA FRENO - MASTER CYLINDERS Ø 19,05 - 3/4"		M1	M2
		M3	M4
		Uscita Olio - Oil exit	
PF266	Olío freni DOT3-4 - Brake oil DOT3-4	Yale - Hyster	

POMPA FRENO - MASTER CYLINDERS Ø 19,05 - 3/4"		M1	M2
		M3	M4
		Uscita Olio - Oil exit	
PF267	Olío freni DOT3-4 - Brake oil DOT3-4	TCM	

POMPA FRENO - MASTER CYLINDERS Ø 19,05 - 3/4"		M1	M2
		M3	M4
		Uscita Olio - Oil exit	
PF039	Olío freni DOT3-4 - Brake oil DOT3-4	Toyota	



I nostri ricambi non sono originali ma con essi perfettamente intercambiabili
 Our spare parts are not original but with them perfectly interchangeable

A01

POMPE FRENO Ø 19.05 - 3/4"
MASTER CYLINDERS Ø 19.05 - 3/4"

**A
01**

POMPA FRENO - MASTER CYLINDERS Ø 19,05 - 3/4"

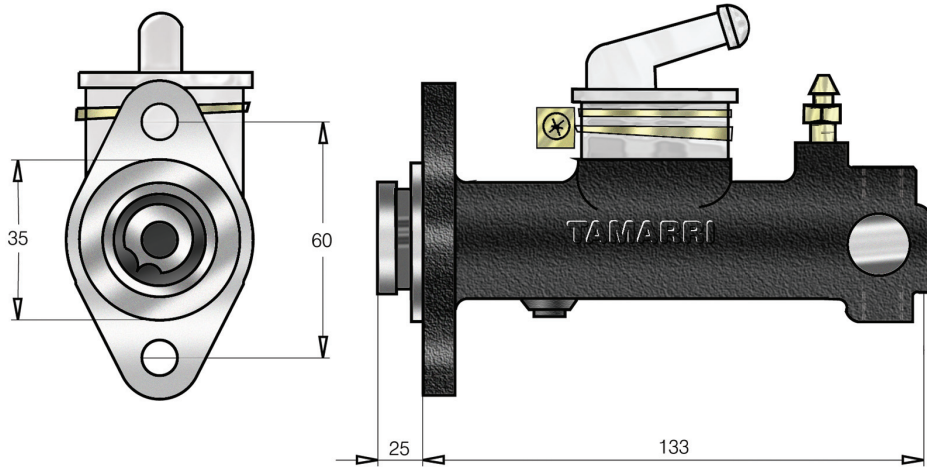

PF318

Olio freni DOT3-4 - Brake oil DOT3-4

Komatsu - Halla

M1

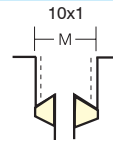

M2

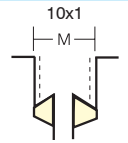

M3

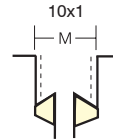

M4

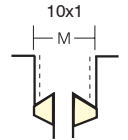

Uscita Olio - Oil exit

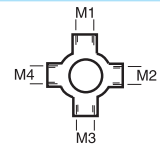

POMPA FRENO - MASTER CYLINDERS Ø 19,05 - 3/4"

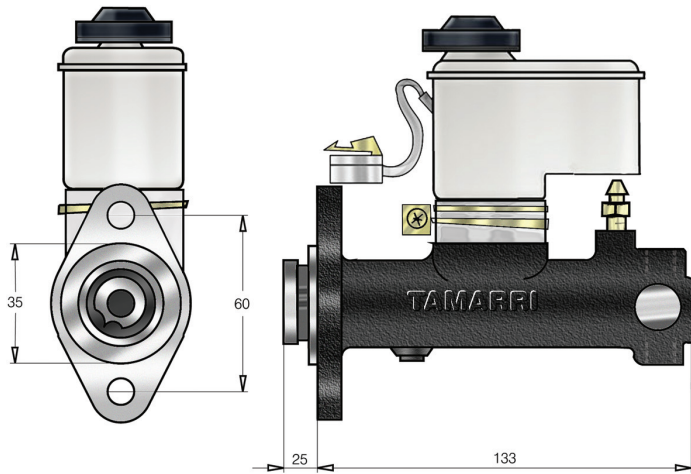

PF276

Olio freni DOT3-4 - Brake oil DOT3-4

M1

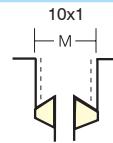

M2

M3

M4

Uscita Olio - Oil exit

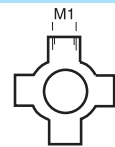

POMPA FRENO - MASTER CYLINDERS Ø 19,05 - 3/4"

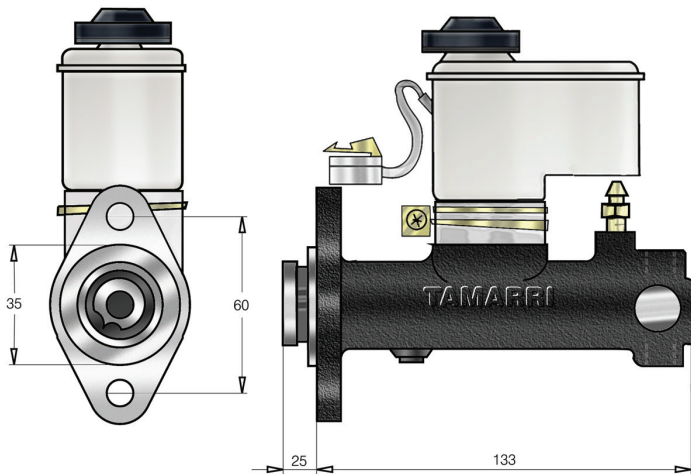

PF055

Olio freni DOT3-4 - Brake oil DOT3-4

Komatsu

M1

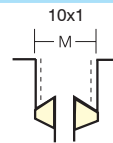

M2

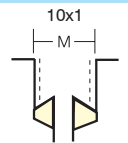

M3

M4

Uscita Olio - Oil exit



I nostri ricambi non sono originali ma con essi perfettamente intercambiabili
 Our spare parts are not original but with them perfectly interchangeable



POMPE FRENO Ø 19.05 - 3/4"
MASTER CYLINDERS Ø 19.05 - 3/4"

**A
01**

POMPA FRENO - MASTER CYLINDERS Ø 19,05 - 3/4"

M1	M2
10x1 M	10x1 M
M3	M4
Uscita Olio - Oil exit	
M2	
M1	

PF281 Olio freni DOT3-4 - Brake oil DOT3-4

POMPA FRENO - MASTER CYLINDERS Ø 19,05 - 3/4"

M1	M2
10x1 M	10x1 M
M3	M4
Uscita Olio - Oil exit	
M1	
M2	

PF432 Olio freni DOT3-4 - Brake oil DOT3-4 TCM

POMPA FRENO - MASTER CYLINDERS Ø 19,05 - 3/4"

M1	M2
10x1 M	
M3	M4
Uscita Olio - Oil exit	
M1	

PF460 Olio freni DOT3-4 - Brake oil DOT3-4 TCM



I nostri ricambi non sono originali ma con essi perfettamente intercambiabili
 Our spare parts are not original but with them perfectly interchangeable

A01

POMPE FRENO Ø 19.05 - 3/4"
MASTER CYLINDERS Ø 19.05 - 3/4"

**A
01**

POMPA FRENO - MASTER CYLINDERS Ø 19,05 - 3/4"

M1	M2
10x1 M	
M3	M4
Uscita Olio - Oil exit	

PF030 Olio freni DOT3-4 - Brake oil DOT3-4 TCM

POMPA FRENO - MASTER CYLINDERS Ø 19,05 - 3/4"

M1	M2
12x1.25 M	
M3	M4
Uscita Olio - Oil exit	

PF311/A Olio freni DOT3-4 - Brake oil DOT3-4 Cesab

POMPA FRENO - MASTER CYLINDERS Ø 19,05 - 3/4"

M1	M2
12x1 M	
M3	M4
Uscita Olio - Oil exit	

PF061 Olio freni DOT3-4 - Brake oil DOT3-4 Lugli



I nostri ricambi non sono originali ma con essi perfettamente intercambiabili
 Our spare parts are not original but with them perfectly interchangeable



POMPE FRENO Ø 19.05 - 3/4"
MASTER CYLINDERS Ø 19.05 - 3/4"

**A
01**

POMPA FRENO - MASTER CYLINDERS Ø 19,05 - 3/4"

M1	M2
M3	M4
Uscita Olio - Oil exit	

PF075 *Olío freni DOT3-4 - Brake oil DOT3-4* *Lugli*

POMPA FRENO - MASTER CYLINDERS Ø 19,05 - 3/4"

M1	M2
M3	M4
Uscita Olio - Oil exit	

PF483M *Olío minerale - Mineral oil* *Same*

POMPA FRENO - MASTER CYLINDERS Ø 19,05 - 3/4"

M1	M2
M3	M4
Uscita Olio - Oil exit	

PF357M *Olío minerale - Mineral oil* *Same*



I nostri ricambi non sono originali ma con essi perfettamente intercambiabili
 Our spare parts are not original but with them perfectly interchangeable



POMPE FRENO Ø 19.05 - 3/4"
MASTER CYLINDERS Ø 19.05 - 3/4"

**A
01**

POMPA FRENO - MASTER CYLINDERS Ø 19,05 - 3/4"

M1 1/8" G M	M2 10x1 M
M3 10x1 M	M4
Uscita Olio - Oil exit	

PF105 Olio freni DOT3-4 - Brake oil DOT3-4 TCM

POMPA FRENO - MASTER CYLINDERS Ø 19,05 - 3/4"

M1 12x1 M	M2 12x1 M
M3 12x1 M	M4
Uscita Olio - Oil exit	

PF074 Olio freni DOT3-4 - Brake oil DOT3-4 Destra

POMPA FRENO - MASTER CYLINDERS Ø 19,05 - 3/4"

M1 3/8" 24 fil. M	M2 3/8" 24 fil. M
M3 3/8" 24 fil. M	M4
Uscita Olio - Oil exit	

PF084 Olio freni DOT3-4 - Brake oil DOT3-4 MIC



I nostri ricambi non sono originali ma con essi perfettamente intercambiabili
 Our spare parts are not original but with them perfectly interchangeable



POMPE FRENO Ø 19.05 - 3/4"
MASTER CYLINDERS Ø 19.05 - 3/4"

**A
01**

POMPA FRENO - MASTER CYLINDERS Ø 19,05 - 3/4"		M1	M2
		M3	M4
		Uscita Olio - Oil exit	
PF096	Olio freni DOT3-4 - Brake oil DOT3-4	Sambrom	

POMPA FRENO - MASTER CYLINDERS Ø 19,05 - 3/4"		M1	M2
		M3	M4
		Uscita Olio - Oil exit	
PF098	Olio freni DOT3-4 - Brake oil DOT3-4	Sambrom - Fenwick	

POMPA FRENO - MASTER CYLINDERS Ø 19,05 - 3/4"		M1	M2
		M3	M4
		Uscita Olio - Oil exit	
PF029	Olio freni DOT3-4 - Brake oil DOT3-4		



I nostri ricambi non sono originali ma con essi perfettamente intercambiabili
 Our spare parts are not original but with them perfectly interchangeable



POMPE FRENO Ø 19.05 - 3/4"
MASTER CYLINDERS Ø 19.05 - 3/4"

**A
01**

POMPA FRENO - MASTER CYLINDERS Ø 19,05 - 3/4"		M1	M2
		M3	M4
<p>PF044 Olio freni DOT3-4 - Brake oil DOT3-4 Mitsubishi - Komatsu</p>		<p>Uscita Olio - Oil exit</p>	

POMPA FRENO - MASTER CYLINDERS Ø 19,05 - 3/4"		M1	M2
		M3	M4
<p>PF097 Olio freni DOT3-4 - Brake oil DOT3-4 Shinko</p>		<p>Uscita Olio - Oil exit</p>	

POMPA FRENO - MASTER CYLINDERS Ø 19,05 - 3/4"		M1	M2
		M3	M4
<p>PF254 Olio freni DOT3-4 - Brake oil DOT3-4 Toyota</p>		<p>Uscita Olio - Oil exit</p>	





POMPE FRENO Ø 19.05 - 3/4"
MASTER CYLINDERS Ø 19.05 - 3/4"

**A
01**

POMPA FRENO - MASTER CYLINDERS Ø 19,05 - 3/4"		M1	M2
		M3	M4
Uscita Olio - Oil exit			
PF251	Olío freni DOT3-4 - Brake oil DOT3-4	Hyster - Yale	

POMPA FRENO - MASTER CYLINDERS Ø 19,05 - 3/4"		M1	M2
		M3	M4
Uscita Olio - Oil exit			
PF207	Completa di raccordi - Complete with connections	Still	

POMPA FRENO - MASTER CYLINDERS Ø 19,05 - 3/4"		M1	M2
		M3	M4
Uscita Olio - Oil exit			
PF053	Senza raccordi - Without connections	Cesab	





POMPE FRENO Ø 19.05 - 3/4"
MASTER CYLINDERS Ø 19.05 - 3/4"

POMPA FRENO - MASTER CYLINDERS Ø 19,05 - 3/4"		M1	M2
		M3	M4
		Uscita Olio - Oil exit	
PF264	Olio freni DOT3-4 - Brake oil DOT3-4		Cesab

POMPA FRENO - MASTER CYLINDERS Ø 19,05 - 3/4"		M1	M2
		10x1 M	10x1 M
		M3	M4
		Uscita Olio - Oil exit	
PF259	Olio freni DOT3-4 - Brake oil DOT3-4		Landini

POMPA FRENO - MASTER CYLINDERS Ø 19,05 - 3/4"		M1	M2
		10x1 M	10x1 M
		M3	M4
		Uscita Olio - Oil exit	
PF260	Olio freni DOT3-4 - Brake oil DOT3-4		Mitsubishi





POMPE FRENO Ø 19.05 - 3/4"
MASTER CYLINDERS Ø 19.05 - 3/4"

**A
01**

POMPA FRENO - MASTER CYLINDERS Ø 19,05 - 3/4"		M1	M2
		M3	M4
		Uscita Olio - Oil exit	
PF287	Olío freni DOT3-4 - Brake oil DOT3-4	Mitsubishi - Caterpillar	

POMPA FRENO - MASTER CYLINDERS Ø 19,05 - 3/4"		M1	M2
		M3	M4
		Uscita Olio - Oil exit	
PF270	Olío freni DOT3-4 - Brake oil DOT3-4	Toyota	

POMPA FRENO - MASTER CYLINDERS Ø 19,05 - 3/4"		M1	M2
		M3	M4
		Uscita Olio - Oil exit	
PF279	Olío freni DOT3-4 - Brake oil DOT3-4	YAM	



I nostri ricambi non sono originali ma con essi perfettamente intercambiabili
 Our spare parts are not original but with them perfectly interchangeable



POMPE FRENO Ø 19.05 - 3/4"
MASTER CYLINDERS Ø 19.05 - 3/4"

**A
01**

POMPA FRENO - MASTER CYLINDERS Ø 19,05 - 3/4"		M1	M2
		Uscita Olio - Oil exit	
PF295	Olio freni DOT3-4 - Brake oil DOT3-4	Massey Ferguson-Valmet	

POMPA FRENO - MASTER CYLINDERS Ø 19,05 - 3/4"		M1	M2
		Uscita Olio - Oil exit	
PF332M	Olio minerale - Mineral oil	JCB - Massey Ferguson	

POMPA FRENO - MASTER CYLINDERS Ø 19,05 - 3/4"		M1	M2
		Uscita Olio - Oil exit	
PF340M	Olio minerale - Mineral oil	Lansing B. - Linde	





POMPE FRENO Ø 19.05 - 3/4"
MASTER CYLINDERS Ø 19.05 - 3/4"

**A
01**

POMPA FRENO - MASTER CYLINDERS Ø 19,05 - 3/4"		M1	M2
		M3	M4
		Uscita Olio - Oil exit	
PF346	Olío freni DOT3-4 - Brake oil DOT3-4	Steinbok - Boss	

POMPA FRENO - MASTER CYLINDERS Ø 19,05 - 3/4"		M1	M2
		M3	M4
		Uscita Olio - Oil exit	
PF355	Olío freni DOT3-4 - Brake oil DOT3-4	NYK	

POMPA FRENO - MASTER CYLINDERS Ø 19,05 - 3/4"		M1	M2
		M3	M4
		Uscita Olio - Oil exit	
PF377	Olío freni DOT3-4 - Brake oil DOT3-4	TCM	





POMPE FRENO Ø 19.05 - 3/4"
MASTER CYLINDERS Ø 19.05 - 3/4"

POMPA FRENO - MASTER CYLINDERS Ø 19,05 - 3/4"

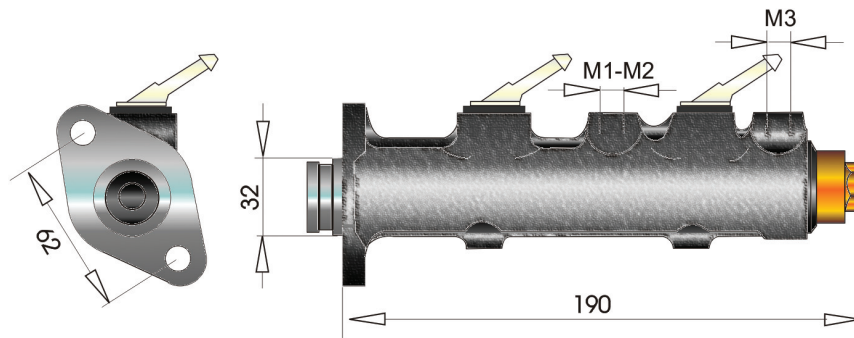

M1 10x1.25 M	M2 10x1.25 M
M3 10x1.25 M	M4
Uscita Olio - Oil exit	
PF394 Olio freni DOT3-4 - Brake oil DOT3-4 Dumper Dumec	

POMPA FRENO - MASTER CYLINDERS Ø 19,05 - 3/4"

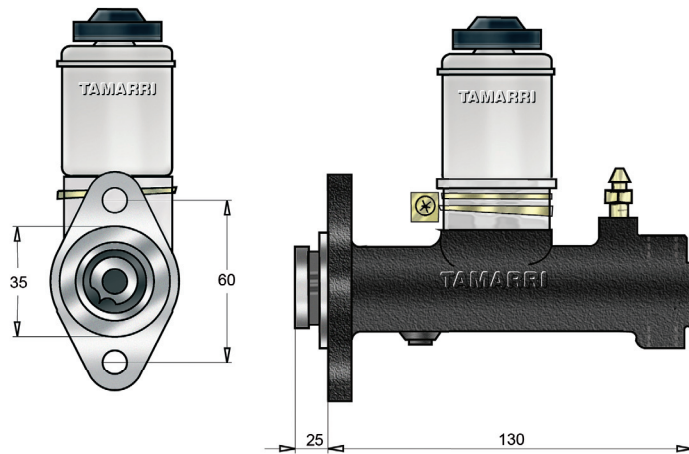

M1 10x1 M	M2 10x1 M
M3	M4
Uscita Olio - Oil exit	
PF395 Olio freni DOT3-4 - Brake oil DOT3-4	

POMPA FRENO - MASTER CYLINDERS Ø 19,05 - 3/4"

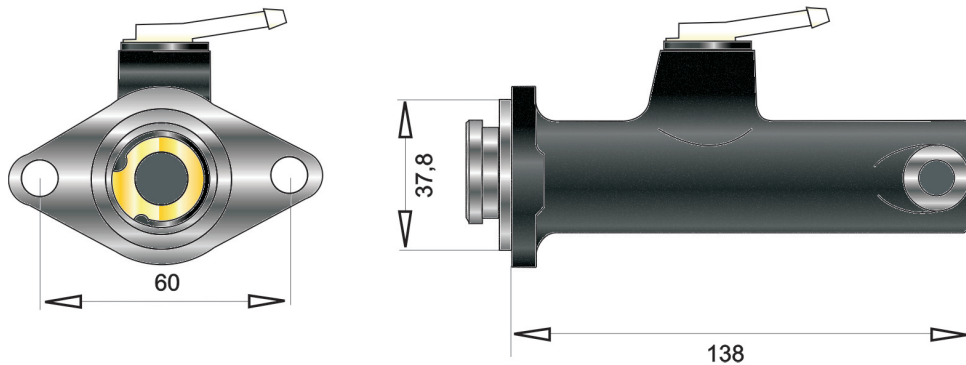

M1 10x1 M	M2 10x1 M
M3	M4
Uscita Olio - Oil exit	
PF406 Olio freni DOT3-4 - Brake oil DOT3-4 Nissan	



I nostri ricambi non sono originali ma con essi perfettamente intercambiabili
 Our spare parts are not original but with them perfectly interchangeable



POMPE FRENO Ø 19.05 - 3/4"
MASTER CYLINDERS Ø 19.05 - 3/4"

**A
01**

POMPA FRENO - MASTER CYLINDERS Ø 19,05 - 3/4"

M1	M2
3/8" 24 fil. M	
M3	M4
Uscita Olio - Oil exit	

PF217 Olio freni DOT3-4 - Brake oil DOT3-4 Shinko - Komatsu

POMPA FRENO - MASTER CYLINDERS Ø 19,05 - 3/4"

M1	M2
3/8" 24 fil. M	
M3	M4
Uscita Olio - Oil exit	

PF201 Olio freni DOT3-4 - Brake oil DOT3-4 Lansing B. - Hyster

POMPA FRENO - MASTER CYLINDERS Ø 19,05 - 3/4"

M1	M2
1/8"-27NPTF M	1/8"-27NPTF M
M3	M4
Uscita Olio - Oil exit	

PF407 Olio freni DOT3-4 - Brake oil DOT3-4 Bobcat





POMPE FRENO Ø 19.05 - 3/4"
MASTER CYLINDERS Ø 19.05 - 3/4"

**A
01**

POMPA FRENO - MASTER CYLINDERS Ø 19,05 - 3/4"		M1	M2
		M3	M4
		Uscita Olio - Oil exit	
PF415	Olio freni DOT3-4 - Brake oil DOT3-4	Caterpillar - Mitsubishi	

POMPA FRENO - MASTER CYLINDERS Ø 19,05 - 3/4"		M1	M2
		M3	M4
		Uscita Olio - Oil exit	
PF348M	Olio minerale - Mineral oil	Still - Linde	

POMPA FRENO - MASTER CYLINDERS Ø 19,05 - 3/4"		M1	M2
		M3	M4
		Uscita Olio - Oil exit	
PF422	Olio freni DOT3-4 - Brake oil DOT3-4	Hyster - Crown	



I nostri ricambi non sono originali ma con essi perfettamente intercambiabili
 Our spare parts are not original but with them perfectly interchangeable



POMPE FRENO Ø 19.05 - 3/4"
MASTER CYLINDERS Ø 19.05 - 3/4"

**A
01**

POMPA FRENO - MASTER CYLINDERS Ø 19,05 - 3/4"

M1	M2
M3	M4
Uscita Olio - Oil exit	

PF425 Olio freni DOT3-4 - Brake oil DOT3-4 Nissan

POMPA FRENO - MASTER CYLINDERS Ø 19,05 - 3/4"

M1	M2
M3	M4
Uscita Olio - Oil exit	

PF426 Olio freni DOT3-4 - Brake oil DOT3-4 Nissan

POMPA FRENO - MASTER CYLINDERS Ø 19,05 - 3/4"

M1	M2
M3	M4
Uscita Olio - Oil exit	

PF427 Olio freni DOT3-4 - Brake oil DOT3-4 Lancer Boss



I nostri ricambi non sono originali ma con essi perfettamente intercambiabili
 Our spare parts are not original but with them perfectly interchangeable



POMPE FRENO Ø 19.05 - 3/4"
MASTER CYLINDERS Ø 19.05 - 3/4"

**A
01**

POMPA FRENO - MASTER CYLINDERS Ø 19,05 - 3/4"

M1	M2
10x1 M	
M3	M4
Uscita Olio - Oil exit	

PF429 Olio freni DOT3-4 - Brake oil DOT3-4 Komatsu

POMPA FRENO - MASTER CYLINDERS Ø 19,05 - 3/4"

M1	M2
10x1 M	10x1 M
M3	M4
Uscita Olio - Oil exit	

PF431 Olio freni DOT3-4 - Brake oil DOT3-4 Pimespo

POMPA FRENO - MASTER CYLINDERS Ø 19,05 - 3/4"

M1	M2
3/8" 24 fil. M	
M3	M4
Uscita Olio - Oil exit	

PF057 Olio freni DOT3-4 - Brake oil DOT3-4 Lansing - Hyster - Yale - Jungheinrich



I nostri ricambi non sono originali ma con essi perfettamente intercambiabili
 Our spare parts are not original but with them perfectly interchangeable



POMPE FRENO Ø 19.05 - 3/4"
MASTER CYLINDERS Ø 19.05 - 3/4"

**A
01**

POMPA FRENO - MASTER CYLINDERS Ø 19,05 - 3/4"		M1	M2
		M3	M4
		Uscita Olio - Oil exit	
PF446	Olío freni DOT3-4 - Brake oil DOT3-4	Zetor	

POMPA FRENO - MASTER CYLINDERS Ø 19,05 - 3/4"		M1	M2
		M3	M4
		Uscita Olio - Oil exit	
PF448	Olío freni DOT3-4 - Brake oil DOT3-4	Hyster	

POMPA FRENO - MASTER CYLINDERS Ø 19,05 - 3/4"		M1	M2
		M3	M4
		Uscita Olio - Oil exit	
PF449	Olío freni DOT3-4 - Brake oil DOT3-4		



I nostri ricambi non sono originali ma con essi perfettamente intercambiabili
 Our spare parts are not original but with them perfectly interchangeable



POMPE FRENO Ø 19.05 - 3/4"
MASTER CYLINDERS Ø 19.05 - 3/4"

**A
01**

POMPA FRENO - MASTER CYLINDERS Ø 19,05 - 3/4"

M1	M2
10x1 M	10x1 M
M3	M4
10x1 M	10x1 M
Uscita Olio - Oil exit	

PF458 Olio freni DOT3-4 - Brake oil DOT3-4 Charlate

POMPA FRENO - MASTER CYLINDERS Ø 19,05 - 3/4"

M1	M2
1/2" 20 fil. M	
M3	M4
Uscita Olio - Oil exit	

PF060 Olio freni DOT3-4 - Brake oil DOT3-4 Hyster

POMPA FRENO - MASTER CYLINDERS Ø 19,05 - 3/4"

M1	M2
16x1,5. M	10x1 M
M3	M4
Uscita Olio - Oil exit	

PF464 Olio freni DOT3-4 - Brake oil DOT3-4 Steinbock



I nostri ricambi non sono originali ma con essi perfettamente intercambiabili
 Our spare parts are not original but with them perfectly interchangeable



POMPE FRENO Ø 19.05 - 3/4"
MASTER CYLINDERS Ø 19.05 - 3/4"

**A
01**

POMPA FRENO - MASTER CYLINDERS Ø 19,05 - 3/4"		M1	M2
		M3	M4
PF063 Olio freni DOT3-4 - Brake oil DOT3-4 Matral		Uscita Olio - Oil exit	

POMPA FRENO - MASTER CYLINDERS Ø 19,05 - 3/4"		M1	M2
		M3	M4
PF242 Olio freni DOT3-4 - Brake oil DOT3-4 Komatsu		Uscita Olio - Oil exit	

POMPA FRENO - MASTER CYLINDERS Ø 19,05 - 3/4"		M1-M2	M3-M4
	M5		
PF471 Olio freni DOT3-4 - Brake oil DOT3-4		Uscita Olio - Oil exit	





POMPE FRENO Ø 19.05 - 3/4"
MASTER CYLINDERS Ø 19.05 - 3/4"

**A
01**

POMPA FRENO - MASTER CYLINDERS Ø 19,05 - 3/4"		M1	M2
		M3	M4
		Uscita Olio - Oil exit	
PF229 Olio freni DOT3-4 - Brake oil DOT3-4	TCM		

POMPA FRENO - MASTER CYLINDERS Ø 19,05 - 3/4"		M1	M2
		M3	M4
		Uscita Olio - Oil exit	
PF067 Olio freni DOT3-4 - Brake oil DOT3-4	Zetor - Ursus - Desta - Ticino		