



POMPE FRENO Ø 22,22 - 7/8"
MASTER CYLINDERS Ø 22,22 - 7/8"

**A
01**

| POMPA FRENO - MASTER CYLINDERS Ø 22,22 - 7/8" | | M1 | M2 |
|---|--------------------------------------|---------------------------|----|
| | | | |
| | | M3 | M4 |
| | | Uscita Olio - Oil exit | |
| PF214 | Olio freni DOT3-4 - Brake oil DOT3-4 | Lansing B. - Linde - Yale | |

| POMPA FRENO - MASTER CYLINDERS Ø 22,22 - 7/8" | | M1 | M2 |
|---|---------------------------------------|------------------------|----|
| | | | |
| | | M3 | M4 |
| | | Uscita Olio - Oil exit | |
| PF209 | Fusione in alluminio - Aluminium body | Montini | |
| PF396 | Fusione in ghisa - Iron body | Montini - Omg | |

| POMPA FRENO - MASTER CYLINDERS Ø 22,22 - 7/8" | | M1 | M2 |
|---|--------------------------------------|------------------------|----|
| | | | |
| | | M3 | M4 |
| | | Uscita Olio - Oil exit | |
| PF202/A | Olio freni DOT3-4 - Brake oil DOT3-4 | Cesab | |
| | | | |



I nostri ricambi non sono originali ma con essi perfettamente intercambiabili
 Our spare parts are not original but with them perfectly interchangeable



POMPE FRENO Ø 22,22 - 7/8"
MASTER CYLINDERS Ø 22,22 - 7/8"

**A
01**

POMPA FRENO - MASTER CYLINDERS Ø 22,22 - 7/8"

| | |
|-------------------------------|-----------|
| M1 | M2 |
| 12x1.5 M | |
| M3 | M4 |
| Uscita Olio - Oil exit | |

PF103/A Olio freni DOT3-4 - Brake oil DOT3-4
 Con valvolina - With valve

Robustus

POMPA FRENO - MASTER CYLINDERS Ø 22,22 - 7/8"

| | |
|-------------------------------|-----------|
| M1 | M2 |
| 12x1.25 M | |
| M3 | M4 |
| Uscita Olio - Oil exit | |

PF103/B Olio freni DOT3-4 - Brake oil DOT3-4
 Senza valvolina - Without valve

Cesab

POMPA FRENO - MASTER CYLINDERS Ø 22,22 - 7/8"

| | |
|-------------------------------|-----------|
| M1 | M2 |
| 10x1 M | |
| M3 | M4 |
| Uscita Olio - Oil exit | |

PF103/D Olio freni DOT3-4 - Brake oil DOT3-4
 Con valvolina - With valve

Goldoni



I nostri ricambi non sono originali ma con essi perfettamente intercambiabili
 Our spare parts are not original but with them perfectly interchangeable



POMPE FRENO Ø 22,22 - 7/8"
MASTER CYLINDERS Ø 22,22 - 7/8"

**A
01**

| POMPA FRENO - MASTER CYLINDERS Ø 22,22 - 7/8" | | M1 | M2 |
|---|--|-------------------------------|----|
| | | | |
| | | M3 | M4 |
| | | Uscita Olio - Oil exit | |
| | | | |
| PF206 | Completa di raccordi - With brake fittings | Still - Jungheinrich | |

| POMPA FRENO - MASTER CYLINDERS Ø 22,22 - 7/8" | | M1 | M2 |
|---|--------------------------------------|-------------------------------|----|
| | | | |
| | | M3 | M4 |
| | | Uscita Olio - Oil exit | |
| | | | |
| PF309 | Olio freni DOT3-4 - Brake oil DOT3-4 | Lugli | |

| POMPA FRENO - MASTER CYLINDERS Ø 22,22 - 7/8" | | M1 | M2 |
|---|--------------------------------------|-------------------------------|----|
| | | | |
| | | M3 | M4 |
| | | Uscita Olio - Oil exit | |
| | | | |
| PF200/A | Olio freni DOT3-4 - Brake oil DOT3-4 | Still - Sibicar | |



I nostri ricambi non sono originali ma con essi perfettamente intercambiabili
 Our spare parts are not original but with them perfectly interchangeable



POMPE FRENO Ø 22,22 - 7/8"
MASTER CYLINDERS Ø 22,22 - 7/8"

**A
01**

| POMPA FRENO - MASTER CYLINDERS Ø 22,22 - 7/8" | | M1 | M2 |
|--|--|--------------------------------------|----|
| | | | |
| | | | |
| <p>PF231 Olio freni DOT3-4 - Brake oil DOT3-4 NYK</p> | | <p>Uscita Olio - Oil exit</p> | |

| POMPA FRENO - MASTER CYLINDERS Ø 22,22 - 7/8" | | M1 | M2 |
|--|--|--------------------------------------|----|
| | | | |
| | | | |
| <p>PF308/A Olio freni DOT3-4 - Brake oil DOT3-4 Cesab</p> | | <p>Uscita Olio - Oil exit</p> | |

| POMPA FRENO - MASTER CYLINDERS Ø 22,22 - 7/8" | | M1 | M2 |
|---|--|--------------------------------------|----|
| | | | |
| | | | |
| <p>PF223/A Olio freni DOT3-4 - Brake oil DOT3-4 Matral</p> | | <p>Uscita Olio - Oil exit</p> | |



I nostri ricambi non sono originali ma con essi perfettamente intercambiabili
 Our spare parts are not original but with them perfectly interchangeable

A01

POMPE FRENO Ø 22,22 - 7/8"
MASTER CYLINDERS Ø 22,22 - 7/8"

A
01

POMPA FRENO - MASTER CYLINDERS Ø 22,22 - 7/8"

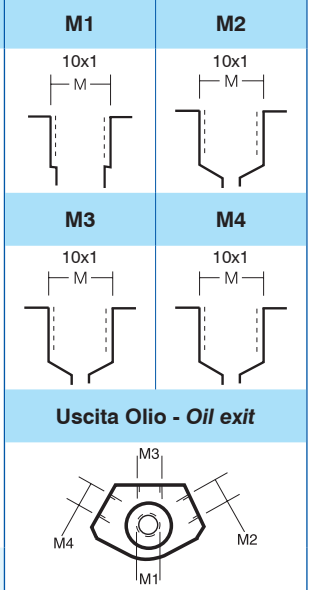
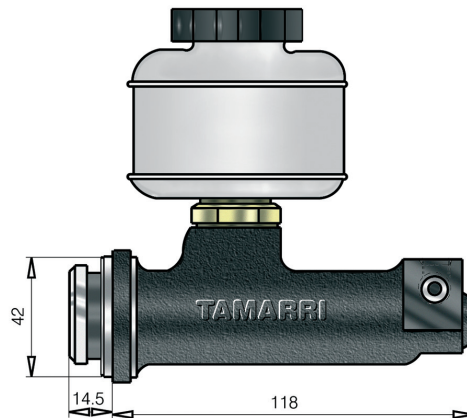
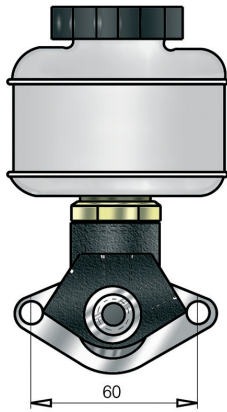

PF205

Olio freni DOT3-4 - Brake oil DOT3-4

Still

POMPA FRENO - MASTER CYLINDERS Ø 22,22 - 7/8"

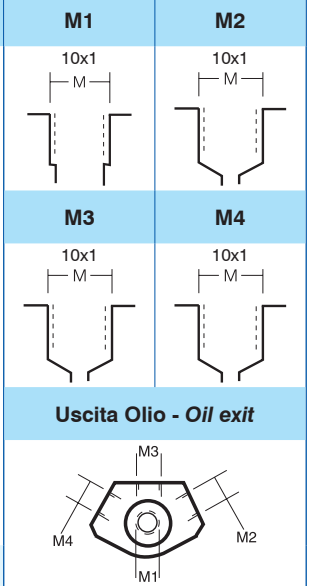
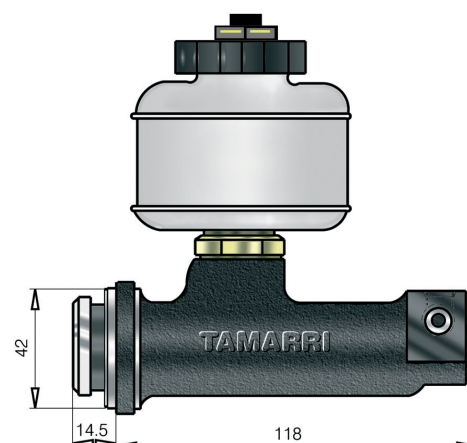
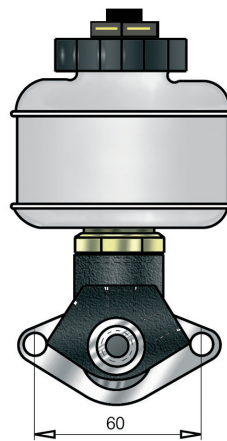

PF410

Olio freni DOT3-4 - Brake oil DOT3-4 *Con sensore livello olio with oil level detecto*

Jungheinrich - Komatsu

POMPA FRENO - MASTER CYLINDERS Ø 22,22 - 7/8"

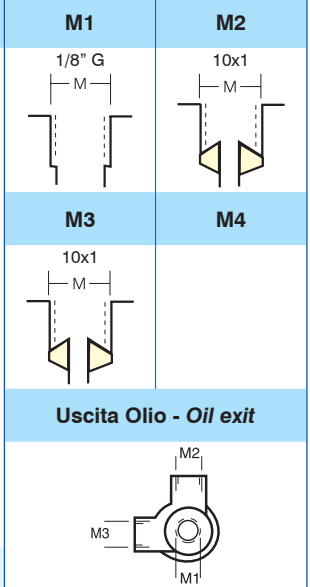
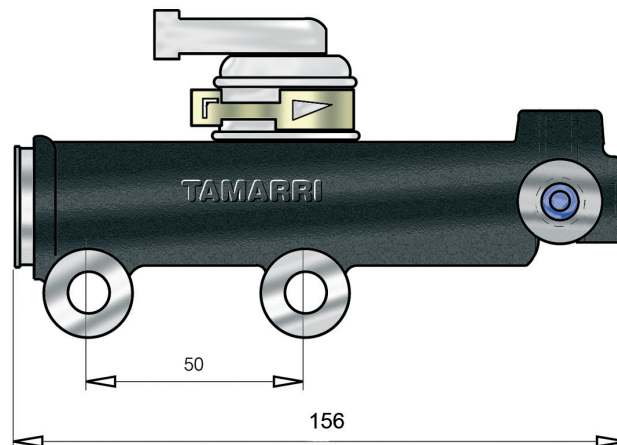
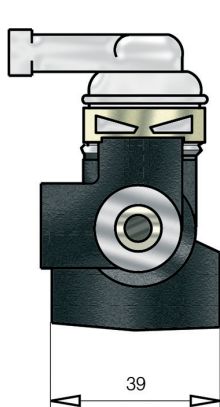

PF218/A

Olio freni DOT3-4 - Brake oil DOT3-4

Mitsubishi



I nostri ricambi non sono originali ma con essi perfettamente intercambiabili
 Our spare parts are not original but with them perfectly interchangeable



POMPE FRENO Ø 22,22 - 7/8"
MASTER CYLINDERS Ø 22,22 - 7/8"

**A
01**

| POMPA FRENO - MASTER CYLINDERS Ø 22,22 - 7/8" | | M1 | M2 |
|---|--------------------------------------|-------------------------------|----|
| | | | |
| | | | |
| | | Uscita Olio - Oil exit | |
| | | | |
| PF087 | Olío freni DOT3-4 - Brake oil DOT3-4 | Mitsubishi | |

| POMPA FRENO - MASTER CYLINDERS Ø 22,22 - 7/8" | | M1 | M2 |
|---|---|-------------------------------|----|
| | | | |
| | | | |
| | | Uscita Olio - Oil exit | |
| | | | |
| PF285 | Olío freni DOT3-4 - Brake oil DOT3-4 <i>Con sensore livello olio with oil level detecto</i> | Mitsubishi | |

| POMPA FRENO - MASTER CYLINDERS Ø 22,22 - 7/8" | | M1 | M2 |
|---|--------------------------------------|-------------------------------|----|
| | | | |
| | | | |
| | | Uscita Olio - Oil exit | |
| | | | |
| PF230/B | Olío freni DOT3-4 - Brake oil DOT3-4 | Caterpillar - Clark | |



I nostri ricambi non sono originali ma con essi perfettamente intercambiabili
 Our spare parts are not original but with them perfectly interchangeable



POMPE FRENO Ø 22,22 - 7/8"
MASTER CYLINDERS Ø 22,22 - 7/8"

**A
01**

| POMPA FRENO - MASTER CYLINDERS Ø 22,22 - 7/8" | | M1 | M2 |
|---|--------------------------------------|------------------------|----|
| | | | |
| | | M3 | M4 |
| | | Uscita Olio - Oil exit | |
| PF311/B | Olio freni DOT3-4 - Brake oil DOT3-4 | Cesab | |

| POMPA FRENO - MASTER CYLINDERS Ø 22,22 - 7/8" | | M1 | M2 |
|---|--------------------------------------|------------------------|----|
| | | | |
| | | M3 | M4 |
| | | Uscita Olio - Oil exit | |
| PF234/A | Olio freni DOT3-4 - Brake oil DOT3-4 | Sambrom | |

| POMPA FRENO - MASTER CYLINDERS Ø 22,22 - 7/8" | | M1 | M2 |
|---|---|------------------------|----|
| | | | |
| | | M3 | M4 |
| | | Uscita Olio - Oil exit | |
| PF234/B | Con valvola in ingresso serbatoio - With oil tank valve | Sambrom | |





POMPE FRENO Ø 22,22 - 7/8"
MASTER CYLINDERS Ø 22,22 - 7/8"

**A
01**

POMPA FRENO - MASTER CYLINDERS Ø 22,22 - 7/8"

| | |
|-------------------------------|-----------|
| M1 | M2 |
| 3/8" 24 fil. | |
| M3 | M4 |
| Uscita Olio - Oil exit | |

PF243 Olio freni DOT3-4 - Brake oil DOT3-4 Hyster

POMPA FRENO - MASTER CYLINDERS Ø 22,22 - 7/8"

| | |
|-------------------------------|-------------------|
| M1 | M2 |
| 7/16" 20 fil. | 7/16" 20 fil. |
| M3 | M4 |
| Uscita Olio - Oil exit | |

PF230/E Olio freni DOT3-4 - Brake oil DOT3-4 Clark - Fenwick

POMPA FRENO - MASTER CYLINDERS Ø 22,22 - 7/8"

| | |
|-------------------------------|-----------|
| M1 | M2 |
| 14x1.5 | 12x1 |
| M3 | M4 |
| 10x1 | 12x1 |
| Uscita Olio - Oil exit | |
| | |

PF258M Solo olio minerale - Mineral oil only
PF027 Olio freno dot 3-4 - Brake fluid dot3-4 Cesab - Still



I nostri ricambi non sono originali ma con essi perfettamente intercambiabili
 Our spare parts are not original but with them perfectly interchangeable



POMPE FRENO Ø 22,22 - 7/8"
MASTER CYLINDERS Ø 22,22 - 7/8"

| POMPA FRENO - MASTER CYLINDERS Ø 22,22 - 7/8" | | M1 | M2 |
|---|--------------------------------------|------------------------|----|
| | | | |
| | | M3 | M4 |
| | | Uscita Olio - Oil exit | |
| PF031 | Olio freni DOT3-4 - Brake oil DOT3-4 | Caterpillar | |

| POMPA FRENO - MASTER CYLINDERS Ø 22,22 - 7/8" | | M1 | M2 |
|---|--------------------------------------|------------------------|----|
| | | | |
| | | M3 | M4 |
| | | Uscita Olio - Oil exit | |
| PF034 | Olio freni DOT3-4 - Brake oil DOT3-4 | TCM | |

| POMPA FRENO - MASTER CYLINDERS Ø 22,22 - 7/8" | | M1 | M2 |
|---|---|--------------------|----|
| | | | |
| | | M3 | M4 |
| | | 1 | |
| Uscita Olio - Oil exit | | | |
| PF041M | Solo olio minerale - Mineral oil only | Daewoo | |
| PF041 | Olio freno dot 3-4 - Brake fluid dot3-4 | Caterpillar-Daewoo | |





POMPE FRENO Ø 22,22 - 7/8"
MASTER CYLINDERS Ø 22,22 - 7/8"

**A
01**

POMPA FRENO - MASTER CYLINDERS Ø 22,22 - 7/8"

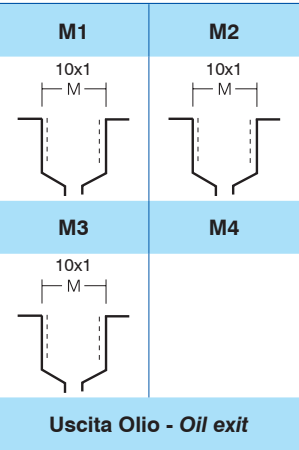
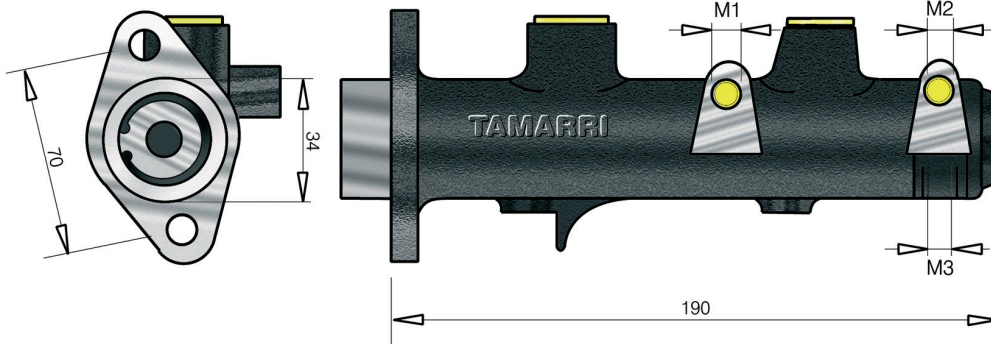

PF050 Olio freni DOT3-4 - Brake oil DOT3-4 Lansing B.

POMPA FRENO - MASTER CYLINDERS Ø 22,22 - 7/8"

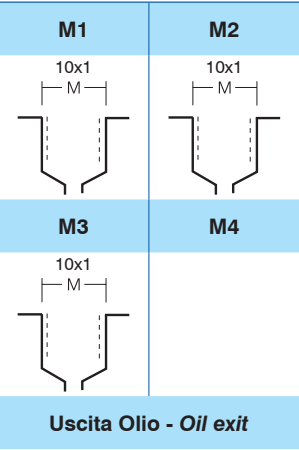
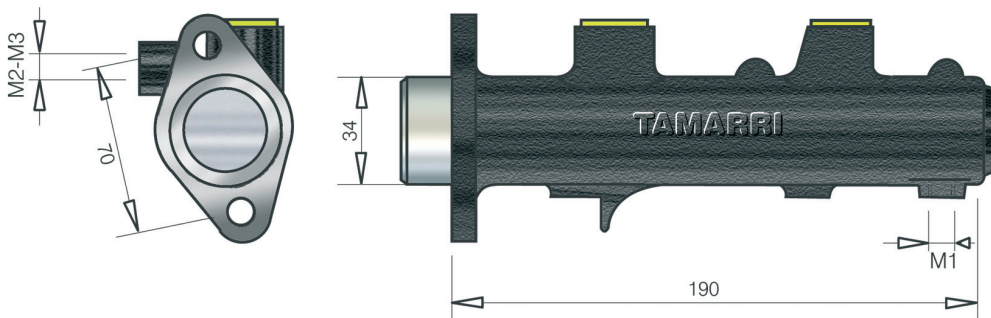

PF327 Olio freni DOT3-4 - Brake oil DOT3-4

POMPA FRENO - MASTER CYLINDERS Ø 22,22 - 7/8"

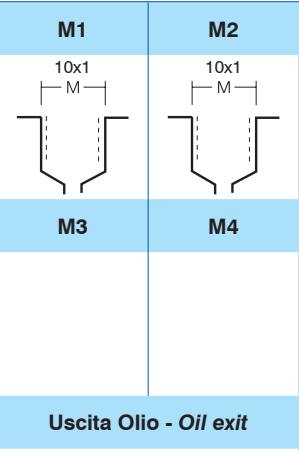
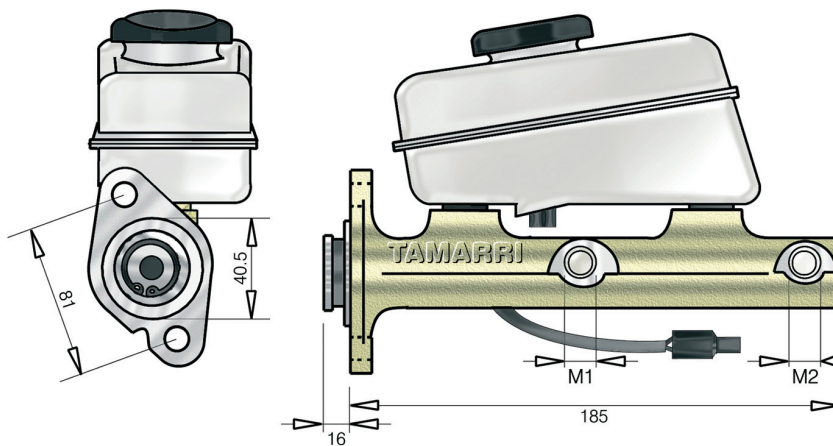

PF054 Olio freni DOT3-4 - Brake oil DOT3-4 Con 2 uscite olio (dx) With 2 exit oil(rh) Jungheinrich - Yale

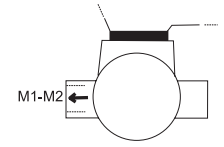

I nostri ricambi non sono originali ma con essi perfettamente intercambiabili
 Our spare parts are not original but with them perfectly interchangeable



POMPE FRENO Ø 22,22 - 7/8"
MASTER CYLINDERS Ø 22,22 - 7/8"

POMPA FRENO - MASTER CYLINDERS Ø 22,22 - 7/8"

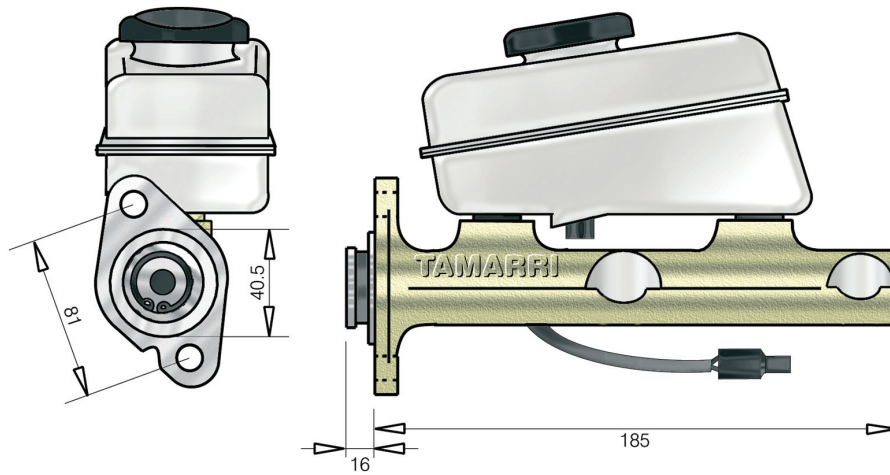

| | |
|-------------------------------|------------------------|
| M1 10x1 M | M2 10x1 M |
| M3 | M4 |
| Uscita Olio - Oil exit | |
| | |

PF369 / Olio freni DOT3-4 - Brake oil DOT3-4 *Con 2 uscite olio (sx) / With 2 exit oil(lh)* Hyster

POMPA FRENO - MASTER CYLINDERS Ø 22,22 - 7/8"

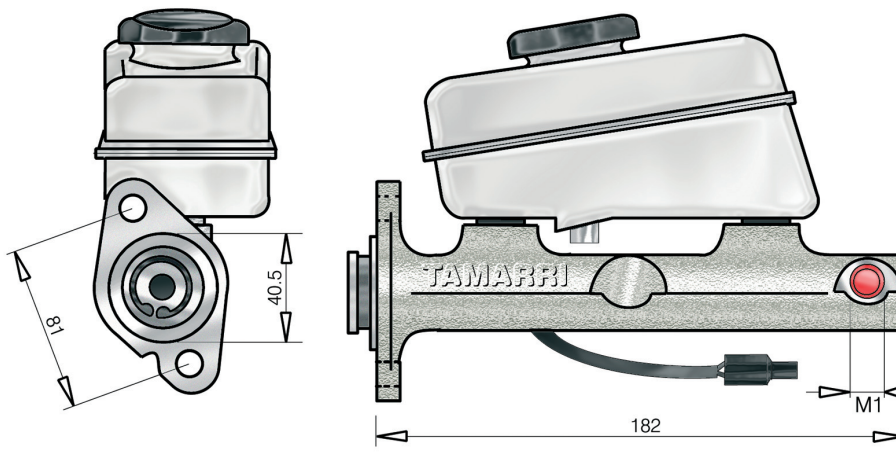

| | |
|-------------------------------|------------------------|
| M1 10x1 M | M2 10x1 M |
| M3 | M4 |
| Uscita Olio - Oil exit | |
| | |

PF094 / Olio freni DOT3-4 - Brake oil DOT3-4 Hyster

POMPA FRENO - MASTER CYLINDERS Ø 22,22 - 7/8"

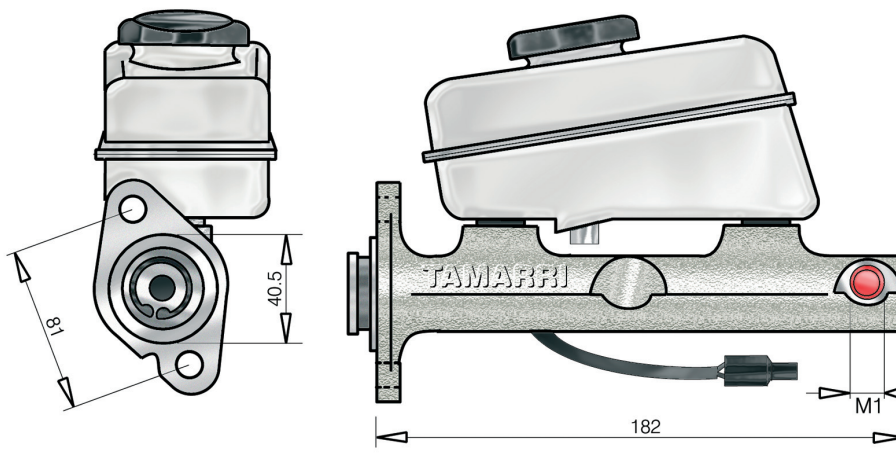

| | |
|-------------------------------|------------------------|
| M1 10x1 M | M2 10x1 M |
| M3 | M4 |
| Uscita Olio - Oil exit | |
| | |

PF419 / Olio freni DOT3-4 - Brake oil DOT3-4 Hyster



I nostri ricambi non sono originali ma con essi perfettamente intercambiabili
 Our spare parts are not original but with them perfectly interchangeable



POMPE FRENO Ø 22,22 - 7/8"
MASTER CYLINDERS Ø 22,22 - 7/8"

**A
01**

| POMPA FRENO - MASTER CYLINDERS Ø 22,22 - 7/8" | | M1 | M2 |
|---|--------------------------------------|------------------------|----|
| | | | |
| | | M3 | M4 |
| | | Uscita Olio - Oil exit | |
| PF086 | Olío freni DOT3-4 - Brake oil DOT3-4 | Anomag | |

| POMPA FRENO - MASTER CYLINDERS Ø 22,22 - 7/8" | | M1 | M2 |
|---|--------------------------------------|------------------------|----|
| | | | |
| | | M3 | M4 |
| | | Uscita Olio - Oil exit | |
| PF248 | Olío freni DOT3-4 - Brake oil DOT3-4 | Cesab | |

| POMPA FRENO - MASTER CYLINDERS Ø 22,22 - 7/8" | | M1 | M2 |
|---|--------------------------------------|------------------------|----|
| | | | |
| | | M3 | M4 |
| | | Uscita Olio - Oil exit | |
| PF256 | Olío freni DOT3-4 - Brake oil DOT3-4 | | |



I nostri ricambi non sono originali ma con essi perfettamente intercambiabili
 Our spare parts are not original but with them perfectly interchangeable

A01

POMPE FRENO Ø 22,22 - 7/8"
MASTER CYLINDERS Ø 22,22 - 7/8"

**A
01**

POMPA FRENO - MASTER CYLINDERS Ø 22,22 - 7/8"

| | |
|-------------------------------|-----------|
| M1 | M2 |
| 10x1 M | |
| M3 | M4 |
| Uscita Olio - Oil exit | |

PF093 Olio freni DOT3-4 - Brake oil DOT3-4 Fenwick

POMPA FRENO - MASTER CYLINDERS Ø 22,22 - 7/8"

| | |
|-------------------------------|-----------|
| M1 | M2 |
| 1/2" 20 fil. M | |
| M3 | M4 |
| Uscita Olio - Oil exit | |

PF068 Olio freni DOT3-4 - Brake oil DOT3-4 Hyster

POMPA FRENO - MASTER CYLINDERS Ø 22,22 - 7/8"

| | |
|-------------------------------|-------------|
| M1 | M2 |
| 10x1 M | 1/8" G M |
| M3 | M4 |
| 10x1 M | |
| Uscita Olio - Oil exit | |
| | |

PF272 Olio freni DOT3-4 - Brake oil DOT3-4 NYK



I nostri ricambi non sono originali ma con essi perfettamente intercambiabili
 Our spare parts are not original but with them perfectly interchangeable



POMPE FRENO Ø 22,22 - 7/8"
MASTER CYLINDERS Ø 22,22 - 7/8"

**A
01**

| POMPA FRENO - MASTER CYLINDERS Ø 22,22 - 7/8" | | M1 | M2 |
|---|--------------------------------------|----|----|
| | | | |
| | | | |
| | Uscita Olio - Oil exit | | |
| PF277 | Olío freni DOT3-4 - Brake oil DOT3-4 | | |

| POMPA FRENO - MASTER CYLINDERS Ø 22,22 - 7/8" | | M1 | M2 |
|---|--------------------------------------|----|----|
| | | | |
| | | | |
| | Uscita Olio - Oil exit | | |
| PF293 | Olío freni DOT3-4 - Brake oil DOT3-4 | | |

| POMPA FRENO - MASTER CYLINDERS Ø 22,22 - 7/8" | | M1 | M2 |
|---|--------------------------------------|----|-----|
| | | | |
| | | | |
| | Uscita Olio - Oil exit | | |
| PF321 | Olío freni DOT3-4 - Brake oil DOT3-4 | | TCM |



I nostri ricambi non sono originali ma con essi perfettamente intercambiabili
 Our spare parts are not original but with them perfectly interchangeable



POMPE FRENO Ø 22,22 - 7/8"
MASTER CYLINDERS Ø 22,22 - 7/8"

**A
01**

POMPA FRENO - MASTER CYLINDERS Ø 22,22 - 7/8"

| | |
|-------------------------------|-----------|
| M1 | M2 |
| 10x1 M | 12x1 M |
| M3 | M4 |
| 12x1 M | |
| Uscita Olio - Oil exit | |

PF333M *Olio minerale - Mineral oil* **JCB**

POMPA FRENO - MASTER CYLINDERS Ø 22,22 - 7/8"

| | |
|-------------------------------|-------------|
| M1 | M2 |
| 10x1 M | 14x1,5 M |
| M3 | M4 |
| 14x1,5 M | |
| Uscita Olio - Oil exit | |

PF439M *Olio minerale - Mineral oil* **Landini**

POMPA FRENO - MASTER CYLINDERS Ø 22,22 - 7/8"

| | |
|-------------------------------|-----------|
| M1 | M2 |
| 10x1 M | 10x1 M |
| M3 | M4 |
| Uscita Olio - Oil exit | |
| | |

PF337 *Olio freni DOT3-4 - Brake oil DOT3-4* **Mitsubishi**



I nostri ricambi non sono originali ma con essi perfettamente intercambiabili
 Our spare parts are not original but with them perfectly interchangeable



POMPE FRENO Ø 22,22 - 7/8"
MASTER CYLINDERS Ø 22,22 - 7/8"

**A
01**

POMPA FRENO - MASTER CYLINDERS Ø 22,22 - 7/8"

| | |
|-------------------------------|-----------|
| M1 | M2 |
| 10x1 M | 12X1 M |
| M3 | M4 |
| 12X1 M | |
| Uscita Olio - Oil exit | |

PF343 Olio freni DOT3-4 - Brake oil DOT3-4 Trattore

POMPA FRENO - MASTER CYLINDERS Ø 22,22 - 7/8"

| | |
|-------------------------------|-----------|
| M1 | M2 |
| 10x1 M | 12x1 M |
| M3 | M4 |
| 12x1 M | |
| Uscita Olio - Oil exit | |

PF360M Olio minerale - Mineral oil JCB

POMPA FRENO - MASTER CYLINDERS Ø 22,22 - 7/8"

| | |
|-------------------------------|-----------|
| M1 | M2 |
| 12x1.5 M | |
| M3 | M4 |
| Uscita Olio - Oil exit | |

PF363 Olio freno dot 3-4 - Brake fluid dot3-4 Montini

PF363M Olio minerale - Mineral oil Robustus - Cesab



I nostri ricambi non sono originali ma con essi perfettamente intercambiabili
 Our spare parts are not original but with them perfectly interchangeable



POMPE FRENO Ø 22,22 - 7/8"
MASTER CYLINDERS Ø 22,22 - 7/8"

| POMPA FRENO - MASTER CYLINDERS Ø 22,22 - 7/8" | | M1 | M2 |
|---|--------------------------------------|------------------------|----|
| | | | |
| | | M3 | M4 |
| | | Uscita Olio - Oil exit | |
| PF364 | Olio freni DOT3-4 - Brake oil DOT3-4 | Johan - Deer | |

| POMPA FRENO - MASTER CYLINDERS Ø 22,22 - 7/8" | | M1 | M2 |
|---|--------------------------------------|------------------------|----|
| | | | |
| | | M3 | M4 |
| | | Uscita Olio - Oil exit | |
| PF373 | Olio freni DOT3-4 - Brake oil DOT3-4 | Fend | |

| POMPA FRENO - MASTER CYLINDERS Ø 22,22 - 7/8" | | M1 | M2 |
|---|---|------------------------|----|
| | | | |
| | | M3 | M4 |
| | | Uscita Olio - Oil exit | |
| PF379M | Olio minerale - Mineral oil | Trattore FIAT | |
| PF379 | Olio freno dot 3-4 - Brake fluid dot3-4 | | |



I nostri ricambi non sono originali ma con essi perfettamente intercambiabili
 Our spare parts are not original but with them perfectly interchangeable



POMPE FRENO Ø 22,22 - 7/8"
MASTER CYLINDERS Ø 22,22 - 7/8"

**A
01**

POMPA FRENO - MASTER CYLINDERS Ø 22,22 - 7/8"

| | |
|--------------------------------|---------------------------------|
| M1 3/8" 24 fil. M | M2 7/16" 20 fil. M |
| M3 | M4 |
| Uscita Olio - Oil exit | |

PF384 Olio freni DOT3-4 - Brake oil DOT3-4 Manitou - Lansing

POMPA FRENO - MASTER CYLINDERS Ø 22,22 - 7/8"

| | |
|-------------------------------|------------------------|
| M1 12x1 M | M2 12x1 M |
| M3 | M4 |
| Uscita Olio - Oil exit | |

PF430M Olio minerale - Mineral oil

POMPA FRENO - MASTER CYLINDERS Ø 22,22 - 7/8"

| | |
|-------------------------------|------------------------|
| M1 1/8" G M | M2 10x1 M |
| M3 10x1 M | M4 |
| Uscita Olio - Oil exit | |

PF079 Olio freni DOT3-4 - Brake oil DOT3-4 Mitsubishi



I nostri ricambi non sono originali ma con essi perfettamente intercambiabili
 Our spare parts are not original but with them perfectly interchangeable

A01

POMPE FRENO Ø 22,22 - 7/8"
MASTER CYLINDERS Ø 22,22 - 7/8"

A
01

| POMPA FRENO - MASTER CYLINDERS Ø 22,22 - 7/8" | | M1 | M2 |
|---|-----------------------------|-------------------------------|----|
| | | | |
| | | M3 | M4 |
| | | Uscita Olio - Oil exit | |
| | | | |
| PF421M | Olio minerale - Mineral oil | Still - Linde | |

| POMPA FRENO - MASTER CYLINDERS Ø 22,22 - 7/8" | | M1 | M2 |
|---|--------------------------------------|-------------------------------|----|
| | | | |
| | | M3 | M4 |
| | | Uscita Olio - Oil exit | |
| PF424 | Olio freni DOT3-4 - Brake oil DOT3-4 | Macchina Operatrice | |

| POMPA FRENO - MASTER CYLINDERS Ø 22,22 - 7/8" | | M1 | M2 |
|---|--------------------------------------|-------------------------------|----|
| | | | |
| | | M3 | M4 |
| | | Uscita Olio - Oil exit | |
| | | | |
| PF237 | Olio freni DOT3-4 - Brake oil DOT3-4 | Still | |



I nostri ricambi non sono originali ma con essi perfettamente intercambiabili
 Our spare parts are not original but with them perfectly interchangeable



POMPE FRENO Ø 22,22 - 7/8"
MASTER CYLINDERS Ø 22,22 - 7/8"

**A
01**

| POMPA FRENO - MASTER CYLINDERS Ø 22,22 - 7/8" | | M1 | M2 |
|---|--------------------------------------|------------------------|----|
| | | | |
| | | M3 | M4 |
| | | Uscita Olio - Oil exit | |
| | | | |
| PF007 | Olio freni DOT3-4 - Brake oil DOT3-4 | OMG | |

| POMPA FRENO - MASTER CYLINDERS Ø 22,22 - 7/8" | | M1 | M2 |
|---|---|------------------------|----|
| | | | |
| | | M3 | M4 |
| | | Uscita Olio - Oil exit | |
| PF436M | Solo olio minerale - Mineral oil only | | |
| PF436 | Olio freno dot 3-4 - Brake fluid dot3-4 | | |

| POMPA FRENO - MASTER CYLINDERS Ø 22,22 - 7/8" | | M1 | M2 |
|---|--|------------------------|----|
| | | | |
| | | M3 | M4 |
| | | Uscita Olio - Oil exit | |
| PF335 | Con servofreno vedi ms175 - With brake booster see ms175 | Hyster | |



I nostri ricambi non sono originali ma con essi perfettamente intercambiabili
 Our spare parts are not original but with them perfectly interchangeable



POMPE FRENO Ø 22,22 - 7/8"
MASTER CYLINDERS Ø 22,22 - 7/8"

**A
01**

POMPA FRENO - MASTER CYLINDERS Ø 22,22 - 7/8"

| | |
|-------------------------------|-----------|
| M1 | M2 |
| 10X1 M | 10X1 M |
| M3 | M4 |
| Uscita Olio - Oil exit | |

PF450 Olio freni DOT3-4 - Brake oil DOT3-4 Fendt

POMPA FRENO - MASTER CYLINDERS Ø 22,22 - 7/8" TANDEM

| | |
|-------------------------------|--------------|
| M1-M2-M3 | M4-M5 |
| 10x1 M | 10x1 M |
| M4 | M5 |
| Uscita Olio - Oil exit | |

TA12947 Olio freni DOT3-4 - Brake oil DOT3-4

POMPA FRENO - MASTER CYLINDERS Ø 22,22 - 7/8"

| | |
|-------------------------------|--------------|
| M1 | M2 |
| 10x1.25 M | 10x1.25 M |
| M3 | M4 |
| Uscita Olio - Oil exit | |

PF300/A Olio freni DOT3-4 - Brake oil DOT3-4 Cesab



I nostri ricambi non sono originali ma con essi perfettamente intercambiabili
 Our spare parts are not original but with them perfectly interchangeable



POMPE FRENO Ø 22,22 - 7/8"
MASTER CYLINDERS Ø 22,22 - 7/8"

**A
01**

| POMPA FRENO - MASTER CYLINDERS Ø 22,22 - 7/8" | | M1 | M2 |
|---|--------------------------------------|------------------------|----|
| | | | |
| | | M3 | M4 |
| | | Uscita Olio - Oil exit | |
| TA23190 | Olío freni DOT3-4 - Brake oil DOT3-4 | Agricolo | |

| POMPA FRENO - MASTER CYLINDERS Ø 22,22 - 7/8" | | M1 | M2 |
|---|---------------------------------------|------------------------|----|
| | | | |
| | | M3 | M4 |
| | | Uscita Olio - Oil exit | |
| TA22117 | Solo olio minerale - Mineral oil only | Agricolo-Ausag | |

| POMPA FRENO - MASTER CYLINDERS Ø 22,22 - 7/8" | | M1 | M2 |
|---|--|------------------------|----|
| | | | |
| | | M3 | M4 |
| | | Uscita Olio - Oil exit | |
| PF473M | Solo olio minerale - Mineral oil only Senza valvola - Without valve | Goldoni | |
| PF473 | Olío freno dot 3-4 - Brake fluid dot3-4 Senza valvola - Without valve | Goldoni | |



I nostri ricambi non sono originali ma con essi perfettamente intercambiabili
 Our spare parts are not original but with them perfectly interchangeable



POMPE FRENO Ø 22,22 - 7/8"
MASTER CYLINDERS Ø 22,22 - 7/8"

**A
01**

| POMPA FRENO - MASTER CYLINDERS Ø 22,22 - 7/8" | | M1 | M2 |
|---|--------------------------------------|------------------------|----|
| | | | |
| | | M3 | M4 |
| | | Uscita Olio - Oil exit | |
| TA22162 | Olío freni DOT3-4 - Brake oil DOT3-4 | Laverda | |

| POMPA FRENO - MASTER CYLINDERS Ø 22,22 - 7/8" | | M1 | M2 |
|---|--|------------------------|----|
| | | | |
| | | M3 | M4 |
| | | Uscita Olio - Oil exit | |
| TA36879 | Olío freni DOT3-4 - Brake oil DOT3-4 Con valvola - With valve | Goldoni | |
| | | | |