



POMPE FRENO Ø 25,4 - 1"
MASTER CYLINDERS Ø 25,4 - 1"

**A
01**

POMPA FRENO - MASTER CYLINDERS Ø 25,4 - 1"		M1	M2
		M3	M4
		Uscita Olio - Oil exit	
PF100	Olio freni DOT3-4 - Brake oil DOT3-4		Caterpillar

POMPA FRENO - MASTER CYLINDERS Ø 25,4 - 1"		M1	M2
		M3	M4
		Uscita Olio - Oil exit	
PF101	Olio freni DOT3-4 - Brake oil DOT3-4		Clark - Hyster - Yale

POMPA FRENO - MASTER CYLINDERS Ø 25,4 - 1"		M1	M2
		M3	M4
		Uscita Olio - Oil exit	
PF101/D	Olio freni DOT3-4 - Brake oil DOT3-4		Hyster - Clark





POMPE FRENO Ø 25,4 - 1"
MASTER CYLINDERS Ø 25,4 - 1"

**A
01**

POMPA FRENO - MASTER CYLINDERS Ø 25,4 - 1"		M1	M2
		M3	M4
		Uscita Olio - Oil exit	
PF301M	Solo olio minerale - Mineral oil only		
PF303	Olío freno DOT 3-4 - Brake fluid DOT 3-4	OM	

POMPA FRENO - MASTER CYLINDERS Ø 25,4 - 1"		M1	M2
		M3	M4
		Uscita Olio - Oil exit	
PF476	Olío freno DOT 3-4 - Brake fluid DOT 3-4 Con valvolina - with valves	Arbos	

POMPA FRENO - MASTER CYLINDERS Ø 25,4 - 1"		M1	M2
		M3	M4
		Uscita Olio - Oil exit	
PF455M	Solo olio minerale - Mineral oil only		
PF454	Olío freno DOT 3-4 - Brake fluid DOT 3-4		



I nostri ricambi non sono originali ma con essi perfettamente intercambiabili
 Our spare parts are not original but with them perfectly interchangeable



POMPE FRENO Ø 25,4 - 1"
MASTER CYLINDERS Ø 25,4 - 1"

**A
01**

POMPA FRENO - MASTER CYLINDERS Ø 25,4 - 1"		M1	M2
			12mm
		M3	M4
		Uscita Olio - Oil exit	
PF465M	Solo olio minerale - Mineral oil only	CESAB	
PF465	Olio freno DOT 3-4 - Brake fluid DOT 3-4	CESAB	

POMPA FRENO - MASTER CYLINDERS Ø 25,4 - 1"		M1	M2
		M3	M4
		Uscita Olio - Oil exit	
PF374M	Solo olio minerale - Mineral oil only		

POMPA FRENO - MASTER CYLINDERS Ø 25,4 - 1"		M1	M2
			1
		M3	M4
		Uscita Olio - Oil exit	
PF480	Olio freno DOT 3-4 - Brake fluid DOT 3-4 Con valvolina - with valves	Laverda	





POMPE FRENO Ø 25,4 - 1"
MASTER CYLINDERS Ø 25,4 - 1"

**A
01**

POMPA FRENO - MASTER CYLINDERS Ø 25,4 - 1"

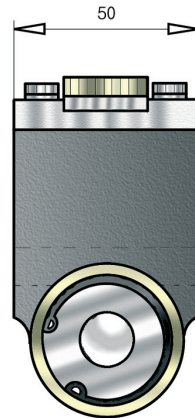
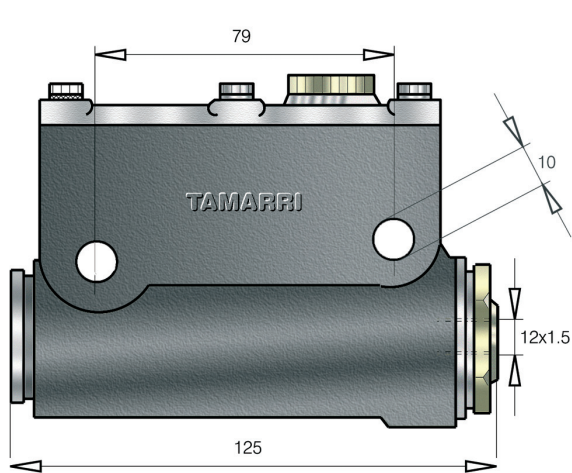

M1	M2
M3	M4
Uscita Olio - Oil exit	

PF103 Olio freni DOT3-4 - Brake oil DOT3-4

Fiori

POMPA FRENO - MASTER CYLINDERS Ø 25,4 - 1"

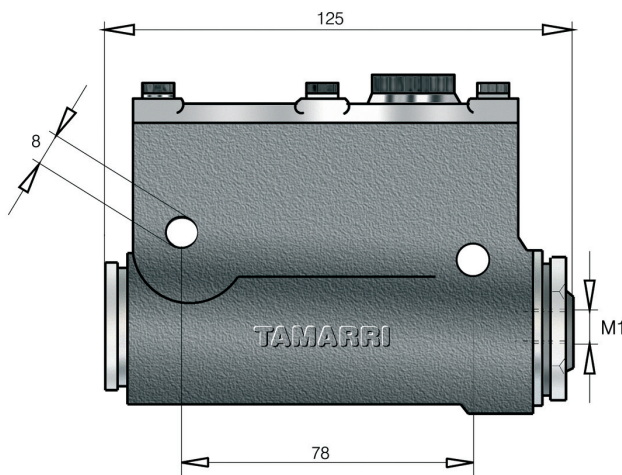

M1	M2
M3	M4
Uscita Olio - Oil exit	

PF080 Olio freni DOT3-4 - Brake oil DOT3-4

Fiori

POMPA FRENO - MASTER CYLINDERS Ø 25,4 - 1"

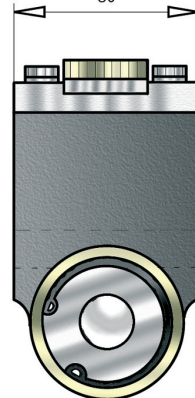
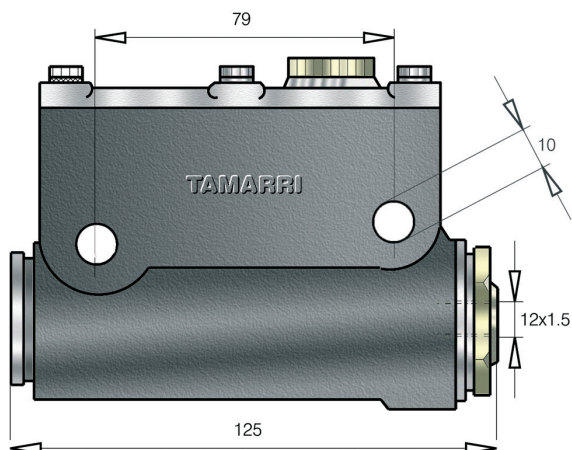

M1	M2
M3	M4
Uscita Olio - Oil exit	

PF103/C Olio freni DOT3-4 - Brake oil DOT3-4
 Senza valvolina - Without valve

Goldoni



I nostri ricambi non sono originali ma con essi perfettamente intercambiabili
 Our spare parts are not original but with them perfectly interchangeable



POMPE FRENO Ø 25,4 - 1"
MASTER CYLINDERS Ø 25,4 - 1"

**A
01**

POMPA FRENO - MASTER CYLINDERS Ø 25,4 - 1"		M1	M2
		M3	M4
PF203 <i>Olío freno DOT 3-4 - Brake fluid DOT 3-4</i>		Uscita Olío - Oil exit	
PF203M <i>Solo olío minerale - Mineral oil only</i>			

POMPA FRENO - MASTER CYLINDERS Ø 25,4 - 1"		M1	M2
		M3	M4
PF389 <i>Olío freni DOT3-4 - Brake oil DOT3-4</i>		Uscita Olío - Oil exit	

POMPA FRENO - MASTER CYLINDERS Ø 25,4 - 1"		M1	M2
		M3	M4
PF203/A <i>Olío freni DOT3-4 - Brake oil DOT3-4</i> Cesab		Uscita Olío - Oil exit	



I nostri ricambi non sono originali ma con essi perfettamente intercambiabili
Our spare parts are not original but with them perfectly interchangeable



POMPE FRENO Ø 25,4 - 1"
MASTER CYLINDERS Ø 25,4 - 1"

**A
01**

POMPA FRENO - MASTER CYLINDERS Ø 25,4 - 1"		M1	M2
		M3	M4
PF437 Olio freni DOT3-4 - <i>Brake oil DOT3-4</i>		Uscita Olio - Oil exit	
PF420M Solo olio minerale - <i>Mineral oil only</i>			
Foredil - Miniescavatori			

POMPA FRENO - MASTER CYLINDERS Ø 25,4 - 1"		M1	M2
		M3	M4
PF219 Olio freni DOT3-4 - <i>Brake oil DOT3-4</i>		Uscita Olio - Oil exit	
Sibicar			

POMPA FRENO - MASTER CYLINDERS Ø 25,4 - 1"		M1	M2
		M3	M4
PF311 Olio freni DOT3-4 - <i>Brake oil DOT3-4</i>		Uscita Olio - Oil exit	
Cesab			



I nostri ricambi non sono originali ma con essi perfettamente intercambiabili
Our spare parts are not original but with them perfectly interchangeable



POMPE FRENO Ø 25,4 - 1"
MASTER CYLINDERS Ø 25,4 - 1"

**A
01**

POMPA FRENO - MASTER CYLINDERS Ø 25,4 - 1"

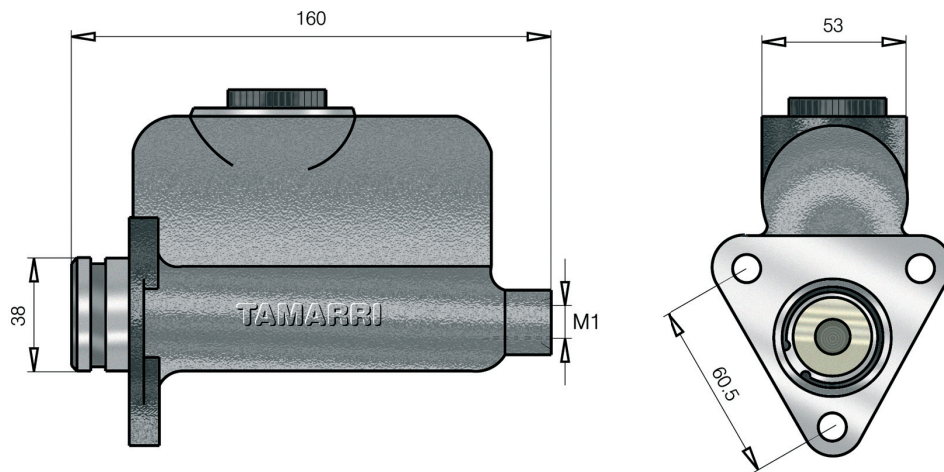

M1	M2
1/2" 20 fil. M	
M3	M4
Uscita Olio - Oil exit	

PF102 Olio freni DOT3-4 - Brake oil DOT3-4

Clark - Hyster - Caterpillar

POMPA FRENO - MASTER CYLINDERS Ø 25,4 - 1"

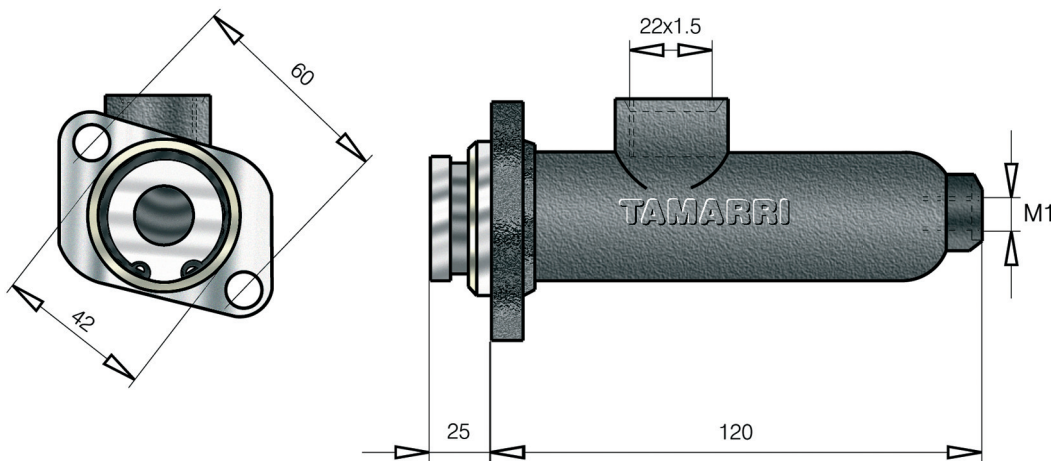

M1	M2
14x1.5 M	
M3	M4
Uscita Olio - Oil exit	

PF314 Olio freni DOT3-4 - Brake oil DOT3-4

O&K - Still - Sibicar

POMPA FRENO - MASTER CYLINDERS Ø 25,4 - 1"

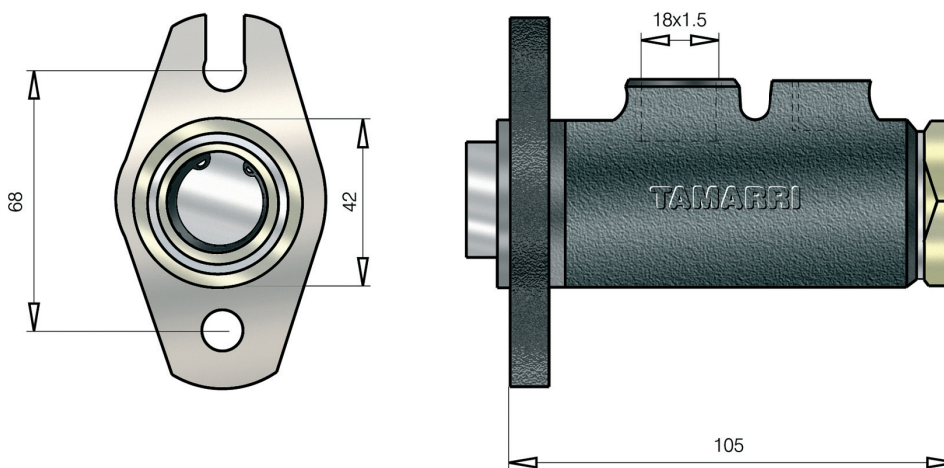

M1	M2
10x1 M	10x1 M
M3	M4
Uscita Olio - Oil exit	

PF313 Olio freni DOT3-4 - Brake oil DOT3-4

Cesab



I nostri ricambi non sono originali ma con essi perfettamente intercambiabili
Our spare parts are not original but with them perfectly interchangeable

A01 **POMPE FRENO Ø 25,4 - 1"**
MASTER CYLINDERS Ø 25,4 - 1"

**A
01**

POMPA FRENO - MASTER CYLINDERS Ø 25,4 - 1"

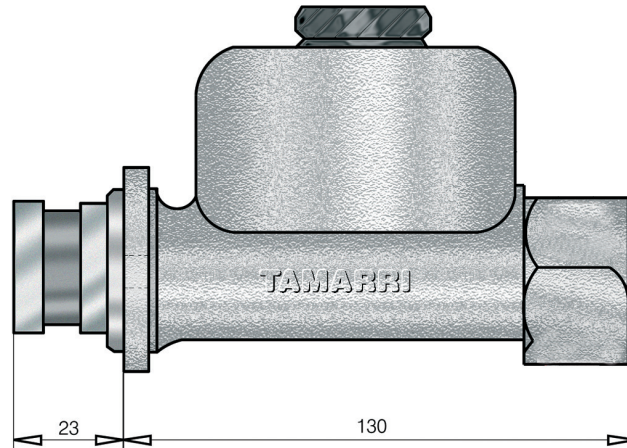
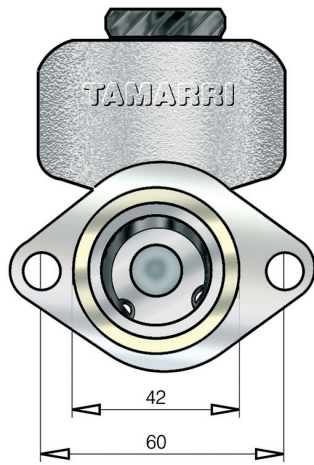

M1 10x1 M	M2 12x1 M
M3 12x1 M	M4
Uscita Olio - Oil exit	

PF233 Olio freni DOT3-4 - Brake oil DOT3-4

Deantoni

POMPA FRENO - MASTER CYLINDERS Ø 25,4 - 1"

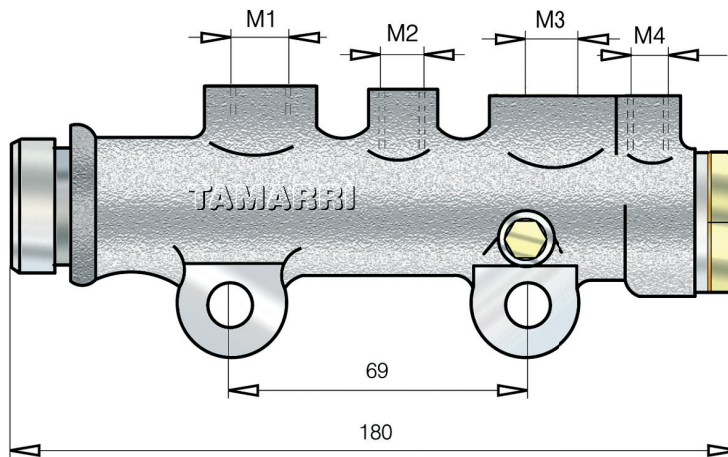
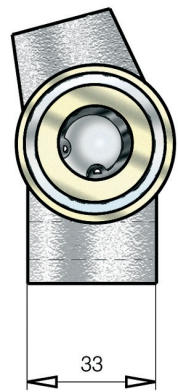

M1 18x1.5 M	M2 10x1.25 M
M3 18x1.5 M	M4 10x1.25 M
Uscita Olio - Oil exit	

PF300 Olio freni DOT3-4 - Brake oil DOT3-4

Benfra - OM

POMPA FRENO - MASTER CYLINDERS Ø 25,4 - 1"

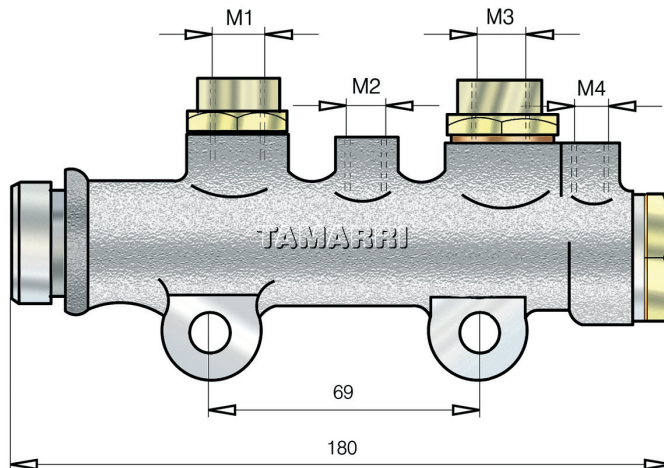
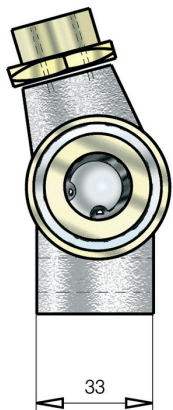

M1 12x1 M	M2 10x1.25 M
M3 12x1 M	M4 10x1.25 M
Uscita Olio - Oil exit	

PF300/B Applicazione speciale - Special application

Benfra - OM



I nostri ricambi non sono originali ma con essi perfettamente intercambiabili
 Our spare parts are not original but with them perfectly interchangeable

A01

POMPE FRENO Ø 25,4 - 1"
MASTER CYLINDERS Ø 25,4 - 1"

**A
01**

POMPA FRENO - MASTER CYLINDERS Ø 25,4 - 1"

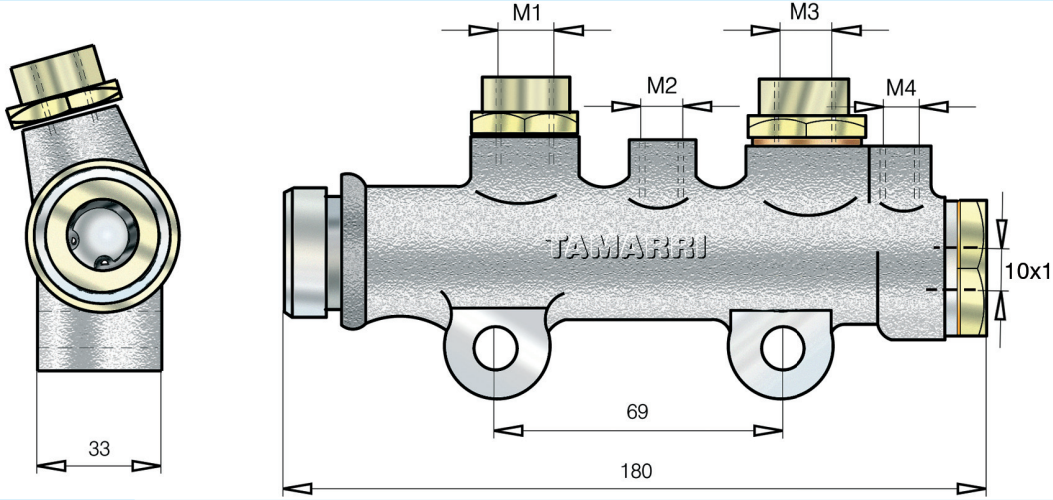

M1 10x1.25 M	M2 10x1.25 M
M3 10x1.25 M	M4 10x1.25 M
Uscita Olio - Oil exit	

PF470

Applicazione speciale - *Special application*

Goldoni

POMPA FRENO - MASTER CYLINDERS Ø 25,4 - 1"

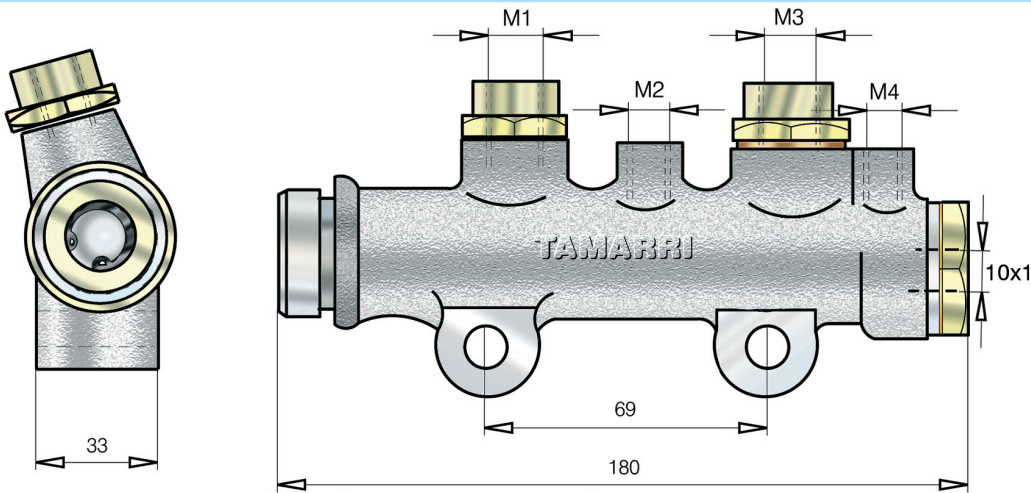

M1 12x1.25 M	M2 10x1.25 M
M3 12x1.25 M	M4 10x1.25 M
Uscita Olio - Oil exit	

TA27335

Applicazione speciale - *Special application*

Goldoni

POMPA FRENO - MASTER CYLINDERS Ø 25,4 - 1"

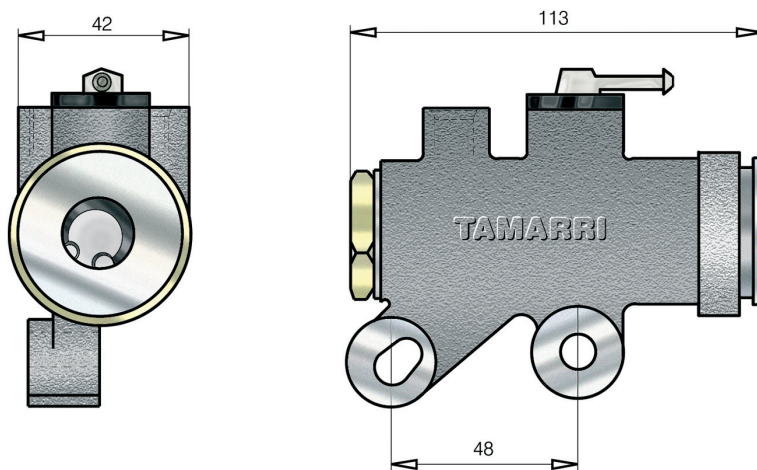

M1 10x1 M	M2 10x1 M
M3 1/8" G M	M4
Uscita Olio - Oil exit	

PF308/B

Olío freni DOT3-4 - *Brake oil DOT3-4*

Cesab



I nostri ricambi non sono originali ma con essi perfettamente intercambiabili
Our spare parts are not original but with them perfectly interchangeable



POMPE FRENO Ø 25,4 - 1"
MASTER CYLINDERS Ø 25,4 - 1"

**A
01**

POMPA FRENO - MASTER CYLINDERS Ø 25,4 - 1"

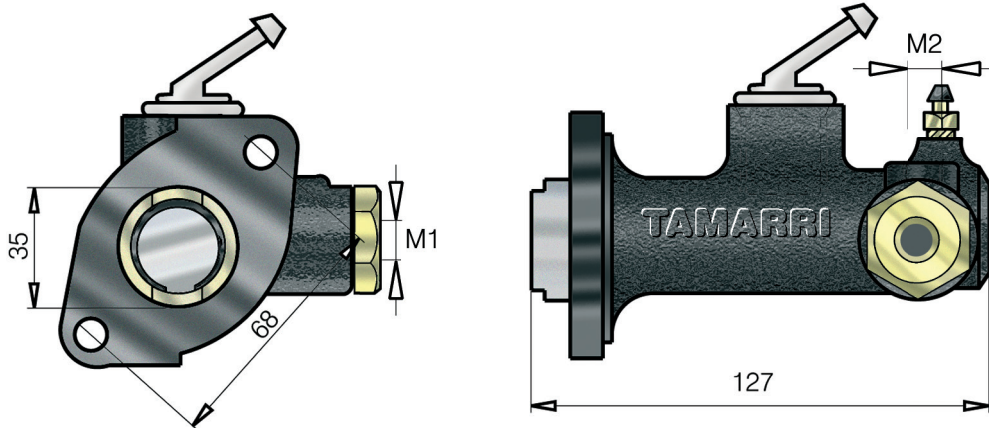

M1	M2
3/8" 24 fil M	1/8" G M
M3	M4
Uscita Olio - Oil exit	

PF317 Olio freni DOT3-4 - Brake oil DOT3-4 Hyster

POMPA FRENO - MASTER CYLINDERS Ø 25,4 - 1"

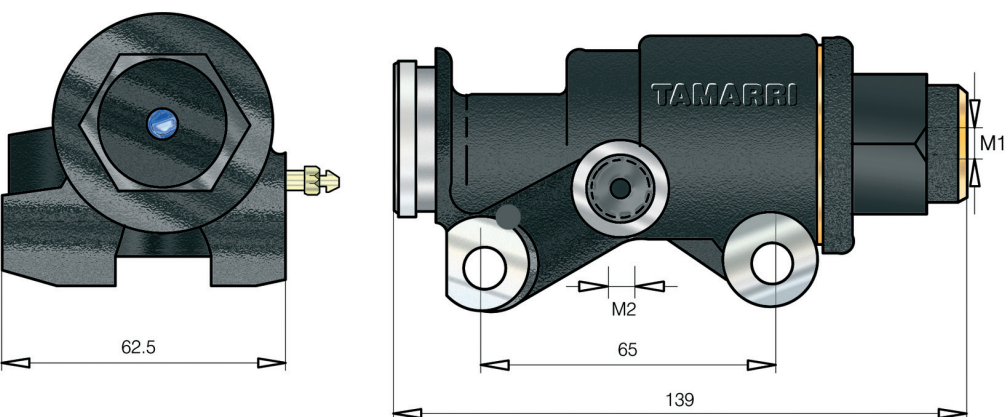

M1	M2
10x1 M	16x1.5 M
M3	M4
Uscita Olio - Oil exit	

PF221/A Olio freni DOT3-4 - Brake oil DOT3-4 Toyota

POMPA FRENO - MASTER CYLINDERS Ø 25,4 - 1"

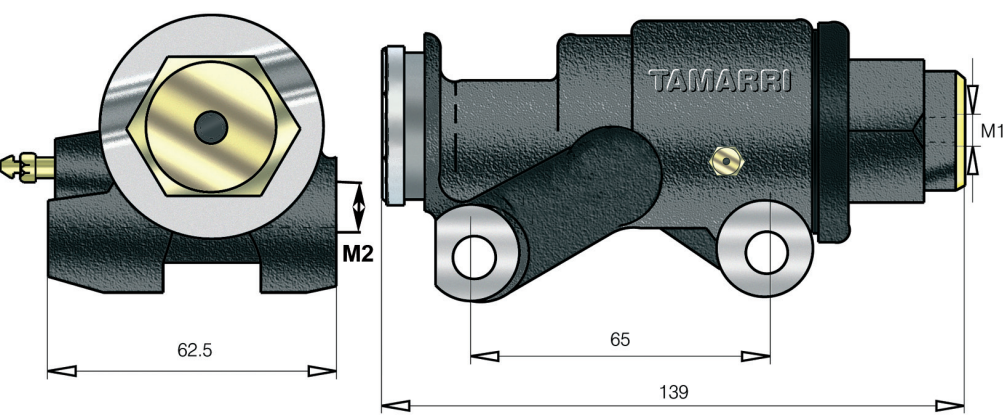

M1	M2
10x1 M	16x1.5 M
M3	M4
Uscita Olio - Oil exit	

PF411 Olio freni DOT3-4 - Brake oil DOT3-4 Toyota



I nostri ricambi non sono originali ma con essi perfettamente intercambiabili
 Our spare parts are not original but with them perfectly interchangeable

A01

POMPE FRENO Ø 25,4 - 1"
MASTER CYLINDERS Ø 25,4 - 1"

**A
01**

POMPA FRENO - MASTER CYLINDERS Ø 25,4 - 1"

M1	M2
1/2" 20 fil. M	
M3	M4
Uscita Olio - Oil exit	

PF025 Olio freni DOT3-4 - Brake oil DOT3-4 Hyster

POMPA FRENO - MASTER CYLINDERS Ø 25,4 - 1"

M1	M2
3/8" 24 fil. M	
M3	M4
Uscita Olio - Oil exit	

PF032 Olio freni DOT3-4 - Brake oil DOT3-4 Clark

POMPA FRENO - MASTER CYLINDERS Ø 25,4 - 1"

M1	M2
10x1.25 M	10x1.25 M
M3	M4
Uscita Olio - Oil exit	

PF263 Olio freni DOT3-4 - Brake oil DOT3-4 Yale



I nostri ricambi non sono originali ma con essi perfettamente intercambiabili
Our spare parts are not original but with them perfectly interchangeable



POMPE FRENO Ø 25,4 - 1"
MASTER CYLINDERS Ø 25,4 - 1"

**A
01**

POMPA FRENO - MASTER CYLINDERS Ø 25,4 - 1"

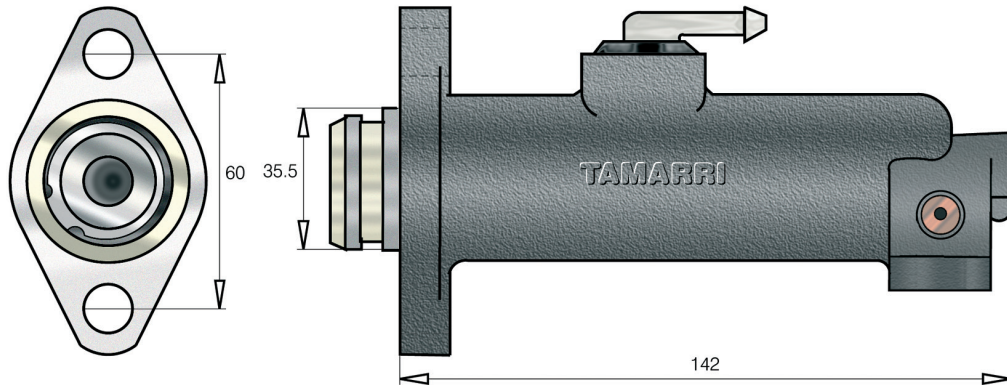

M1 12x1.5 M	M2 12x1.5 M
M3	M4
Uscita Olio - Oil exit	

PF037 Olio freni DOT3-4 - Brake oil DOT3-4

TCM

POMPA FRENO - MASTER CYLINDERS Ø 25,4 - 1"

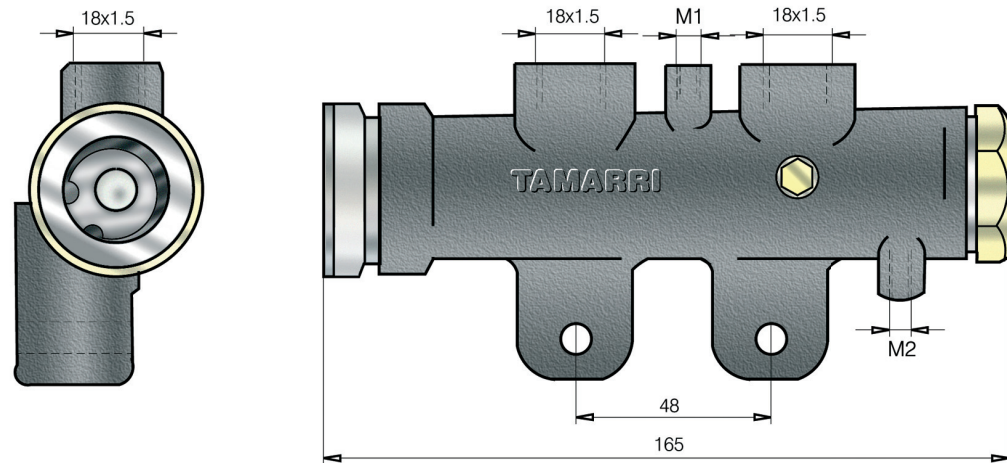

M1 10x1 M	M2 10x1 M
M3	M4
Uscita Olio - Oil exit	

PF040 Olio freni DOT3-4 - Brake oil DOT3-4

Cesab

POMPA FRENO - MASTER CYLINDERS Ø 25,4 - 1"

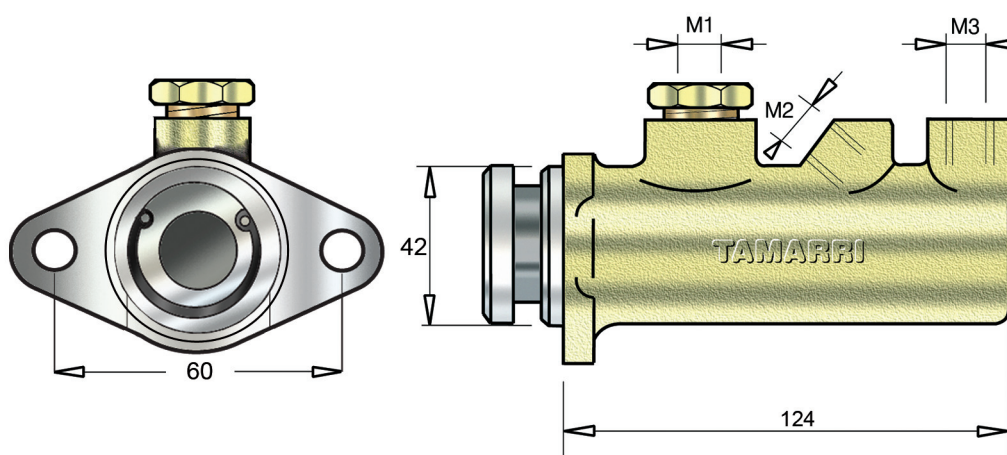

M1 10x1 M	M2 14x1.5 M
M3 14x1.5 M	M4
Uscita Olio - Oil exit	

TA33161 Solo olio minerale - Mineral oil only

Massey Ferguson



I nostri ricambi non sono originali ma con essi perfettamente intercambiabili
Our spare parts are not original but with them perfectly interchangeable



POMPE FRENO Ø 25,4 - 1"
MASTER CYLINDERS Ø 25,4 - 1"

**A
01**

POMPA FRENO - MASTER CYLINDERS Ø 25,4 - 1"		M1	M2
PF051M Solo olio minerale - Mineral oil only International		Uscita Olio - Oil exit	
PF051 Olio freno DOT 3-4 - Brake fluid DOT 3-4			

POMPA FRENO - MASTER CYLINDERS Ø 25,4 - 1"		M1	M2
PF441M Solo olio minerale - Mineral oil only Landini		Uscita Olio - Oil exit	

POMPA FRENO - MASTER CYLINDERS Ø 25,4 - 1"		M1	M2
PF069 Olio freni DOT3-4 - Brake oil DOT3-4 Merlo		Uscita Olio - Oil exit	



I nostri ricambi non sono originali ma con essi perfettamente intercambiabili
 Our spare parts are not original but with them perfectly interchangeable



POMPE FRENO Ø 25,4 - 1"
MASTER CYLINDERS Ø 25,4 - 1"

**A
01**

POMPA FRENO - MASTER CYLINDERS Ø 25,4 - 1"

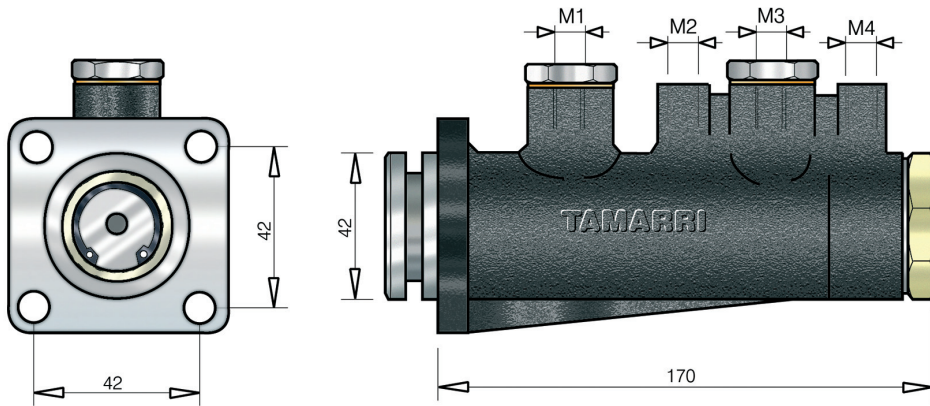

M1 12x1.25 M	M2 10x1.25 M
M3 12x1.25 M	M4 10x1.25 M
Uscita Olio - Oil exit	

PF081 Olio freni DOT3-4 - Brake oil DOT3-4

POMPA FRENO - MASTER CYLINDERS Ø 25,4 - 1"

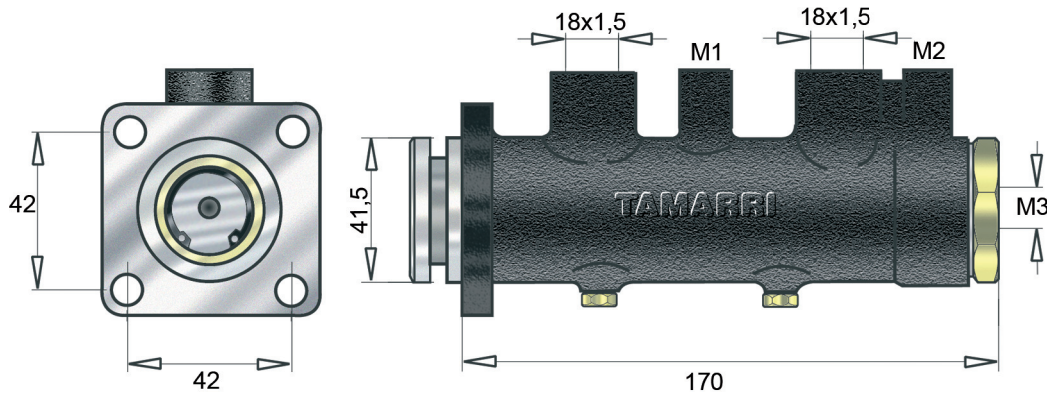

M1 10x1,25 M	M2 10x1,25 M
M3 10x1 M	M4
Uscita Olio - Oil exit	

PF478 Olio freni DOT3-4 - Brake oil DOT3-4 Merlo

POMPA FRENO - MASTER CYLINDERS Ø 25,4 - 1"

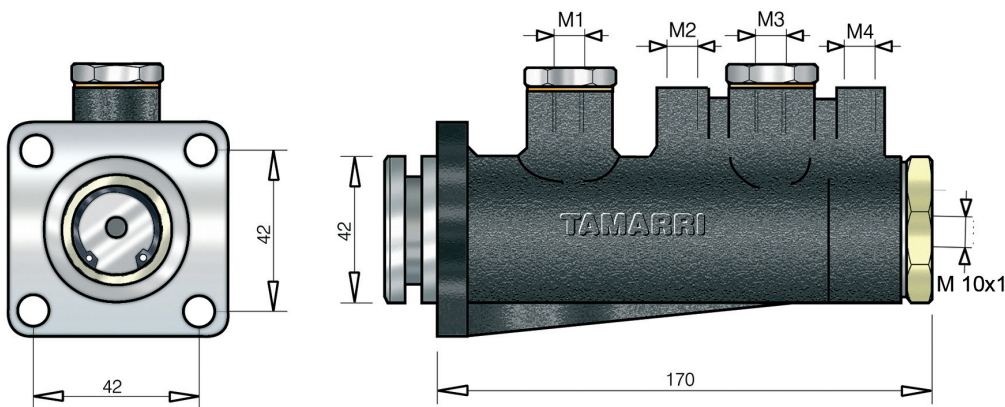

M1 10x1,25 M	M2 10x1,25 M
M3 10x1,25 M	M4 10x1,25 M
Uscita Olio - Oil exit	

PF479 Olio freni DOT3-4 - Brake oil DOT3-4 Goldoni



I nostri ricambi non sono originali ma con essi perfettamente intercambiabili
 Our spare parts are not original but with them perfectly interchangeable



POMPE FRENO Ø 25,4 - 1"
MASTER CYLINDERS Ø 25,4 - 1"

**A
01**

POMPA FRENO - MASTER CYLINDERS Ø 25,4 - 1"		M1	M2
		M3	M4
<p>TA25749 Olio freni DOT3-4 <i>Per servofreno</i> Brake oil DOT3-4 <i>For servo brake</i> Merlo</p>		<p>Uscita Olio - Oil exit</p>	

POMPA FRENO - MASTER CYLINDERS Ø 25,4 - 1"		M1	M2
		M3	M4
<p>PF408 Olio freni DOT3-4 <i>Per pedaliera</i> Brake oil DOT3-4 <i>For brake pedal</i> Merlo</p>		<p>Uscita Olio - Oil exit</p>	

POMPA FRENO - MASTER CYLINDERS Ø 25,4 - 1"		M1	M2
		M3	M4
<p>PF326 Olio freni DOT3-4 - Brake oil DOT3-4 Pgs</p>		<p>Uscita Olio - Oil exit</p>	





POMPE FRENO Ø 25,4 - 1"
MASTER CYLINDERS Ø 25,4 - 1"

**A
01**

POMPA FRENO - MASTER CYLINDERS Ø 25,4 - 1"		M1	M2
		Uscita Olio - Oil exit	
PF085	Solo olio minerale - Mineral oil only		Clark

POMPA FRENO - MASTER CYLINDERS Ø 25,4 - 1"		M1	M2
		Uscita Olio - Oil exit	
PF283M	Solo olio minerale - Mineral oil only		Manitou

POMPA FRENO - MASTER CYLINDERS Ø 25,4 - 1"		M1	M2
		Uscita Olio - Oil exit	
PF284	Olio freni DOT3-4 - Brake oil DOT3-4		Lancer B. - Steinbok - MIC



I nostri ricambi non sono originali ma con essi perfettamente intercambiabili
Our spare parts are not original but with them perfectly interchangeable

A01

POMPE FRENO Ø 25,4 - 1"
MASTER CYLINDERS Ø 25,4 - 1"

**A
01**

POMPA FRENO - MASTER CYLINDERS Ø 25,4 - 1"

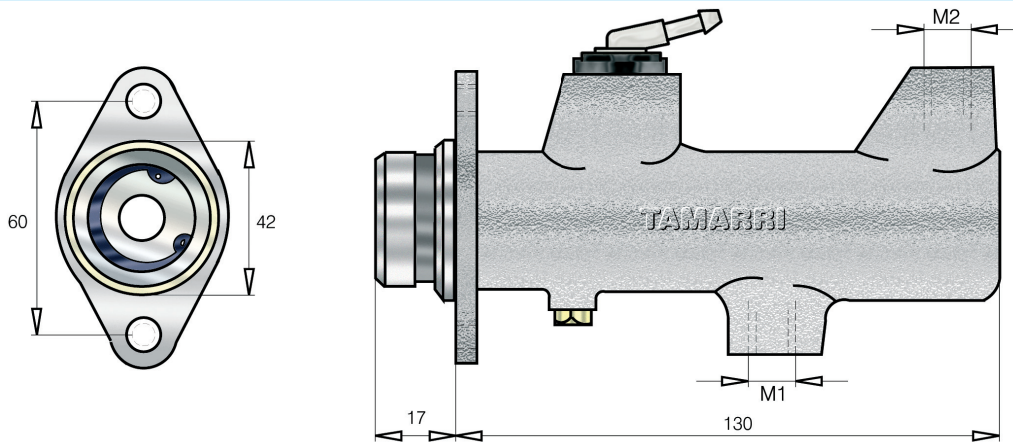

M1	M2
12x1.25 M	12x1.25 M
M3	M4
Uscita Olio - Oil exit	

PF036 Olio minerale - Mineral oil FAI - SAME
PF298 Olio freni DOT3-4 - Brake oil DOT3-4

POMPA FRENO - MASTER CYLINDERS Ø 25,4 - 1"

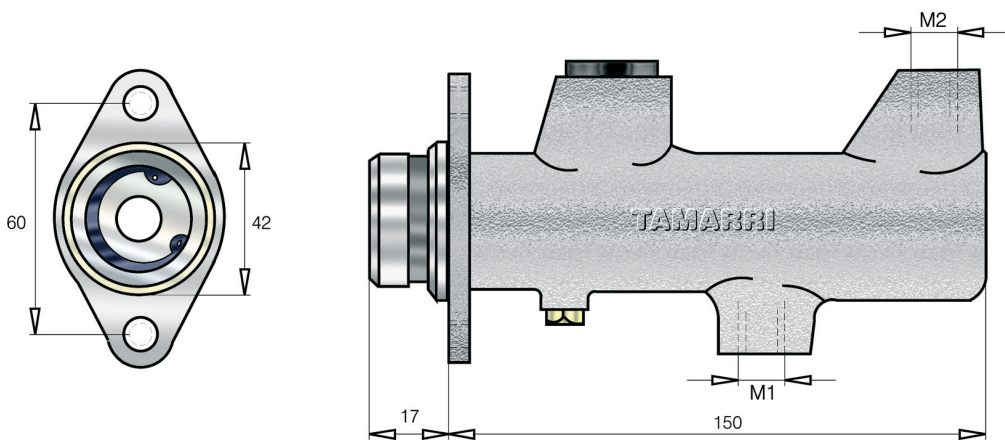

M1	M2
12x1.25 M	12x1.25 M
M3	M4
Uscita Olio - Oil exit	

PF359M Olio minerale - Mineral oil

POMPA FRENO - MASTER CYLINDERS Ø 25,4 - 1"

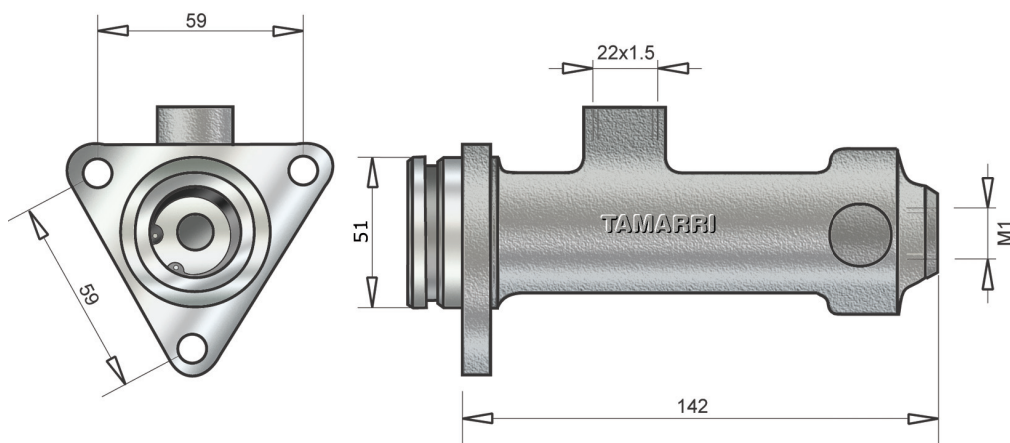

M1	M2
14x1.5 M	
M3	M4
Uscita Olio - Oil exit	

PF062 Olio freni DOT3-4 - Brake oil DOT3-4 Yale



I nostri ricambi non sono originali ma con essi perfettamente intercambiabili
 Our spare parts are not original but with them perfectly interchangeable



POMPE FRENO Ø 25,4 - 1"
MASTER CYLINDERS Ø 25,4 - 1"

**A
01**

POMPA FRENO - MASTER CYLINDERS Ø 25,4 - 1"		M1	M2
		M3	M4
PF252 Olio freni DOT3-4 - Brake oil DOT3-4 Nissan		Uscita Olio - Oil exit 	

POMPA FRENO - MASTER CYLINDERS Ø 25,4 - 1"		M1	M2
		M3	M4
PF322 Olio freni DOT3-4 - Brake oil DOT3-4 Balkancar		Uscita Olio - Oil exit	

POMPA FRENO - MASTER CYLINDERS Ø 25,4 - 1"		M1	M2
		M3	M4
PF339M Olio minerale - Mineral oil Lansing B. - Linde		Uscita Olio - Oil exit	



I nostri ricambi non sono originali ma con essi perfettamente intercambiabili
 Our spare parts are not original but with them perfectly interchangeable

A01

POMPE FRENO Ø 25,4 - 1"
MASTER CYLINDERS Ø 25,4 - 1"

**A
01**

POMPA FRENO - MASTER CYLINDERS Ø 25,4 - 1"

M1	M2
10x1 M	
M3	M4
Uscita Olio - Oil exit	

PF353 Olio freni DOT3-4 - Brake oil DOT3-4 Komatsu

POMPA FRENO - MASTER CYLINDERS Ø 25,4 - 1"

M1	M2
10x1 M	
M3	M4
Uscita Olio - Oil exit	

PF381 Olio freni DOT3-4 - Brake oil DOT3-4 Yale

POMPA FRENO - MASTER CYLINDERS Ø 25,4 - 1"

M1	M2
1/2" 20 fil. M	
M3	M4
Uscita Olio - Oil exit	

PF382 Olio freni DOT3-4 - Brake oil DOT3-4



I nostri ricambi non sono originali ma con essi perfettamente intercambiabili
 Our spare parts are not original but with them perfectly interchangeable



POMPE FRENO Ø 25,4 - 1"
MASTER CYLINDERS Ø 25,4 - 1"

**A
01**

POMPA FRENO - MASTER CYLINDERS Ø 25,4 - 1"		M1	M2
		M3	M4
		Uscita Olio - Oil exit	
PF385	Olío freni DOT3-4 - Brake oil DOT3-4	Mitsubishi	

POMPA FRENO - MASTER CYLINDERS Ø 25,4 - 1"		M1	M2
		M3	M4
		Uscita Olio - Oil exit	
PF004	Olío freni DOT3-4 - Brake oil DOT3-4	Simai	

POMPA FRENO - MASTER CYLINDERS Ø 25,4 - 1"		M1	M2
		M3	M4
		Uscita Olio - Oil exit	
PF024	Olío freni DOT3-4 - Brake oil DOT3-4		
PF024M	Olío minerale - Mineral oil		



POMPE FRENO Ø 25,4 - 1"
MASTER CYLINDERS Ø 25,4 - 1"

**A
01**

POMPA FRENO - MASTER CYLINDERS Ø 25,4 - 1"		M1	M2
		M3	M4
		Uscita Olio - Oil exit	
PF414M	Olio minerale - Mineral oil	Cesab	

POMPA FRENO - MASTER CYLINDERS Ø 25,4 - 1"		M1	M2
		M3	M4
		Uscita Olio - Oil exit	
PF417	Olio freni DOT3-4 - Brake oil DOT3-4		

POMPA FRENO - MASTER CYLINDERS Ø 25,4 - 1"		M1	M2
		M3	M4
		Uscita Olio - Oil exit	
PF305	Olio freni DOT3-4 - Brake oil DOT3-4	OM	



I nostri ricambi non sono originali ma con essi perfettamente intercambiabili
Our spare parts are not original but with them perfectly interchangeable



POMPE FRENO Ø 25,4 - 1"
MASTER CYLINDERS Ø 25,4 - 1"

**A
01**

POMPA FRENO - MASTER CYLINDERS Ø 25,4 - 1"

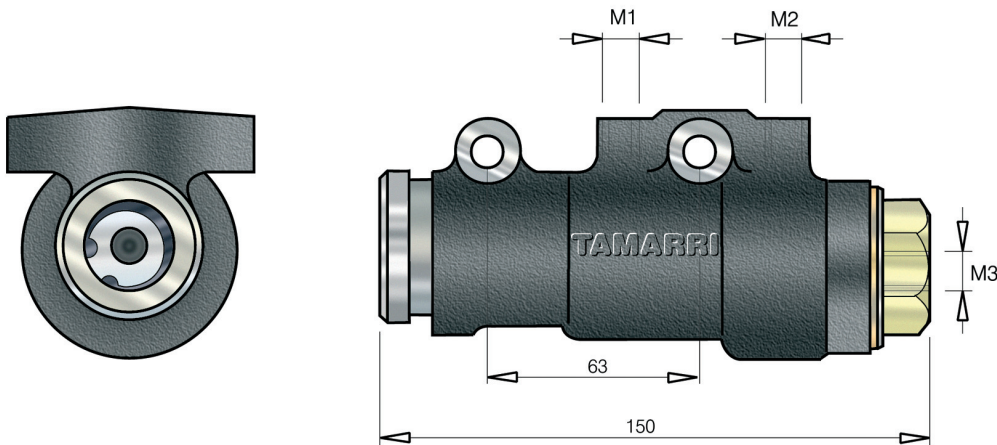

M1 1/2" 20 fil. 	M2 7/16" 20 fil.
M3 3/8" 24 fil. 	M4
Uscita Olio - Oil exit	

PF056 Olio freni DOT3-4 - Brake oil DOT3-4

POMPA FRENO - MASTER CYLINDERS Ø 25,4 - 1"

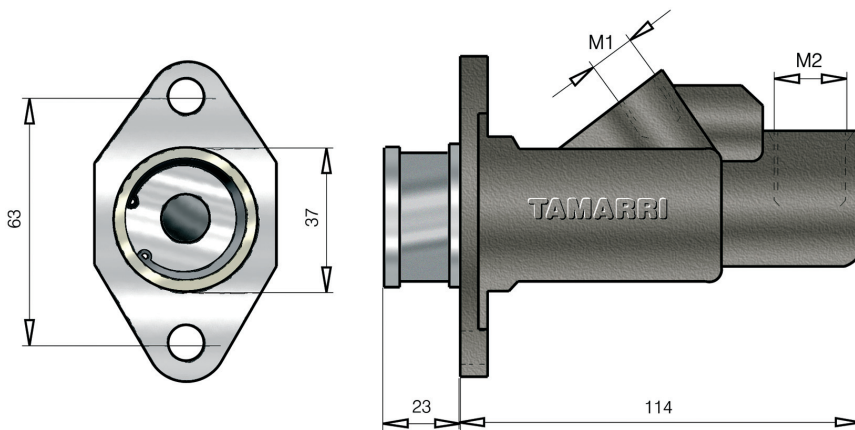

M1 7/16" 20 fil. 	M2 7/16" 20 fil.
M3	M4
Uscita Olio - Oil exit	

PF230 Olio freni DOT3-4 - Brake oil DOT3-4 Hyster - Clark - Caterpillar

POMPA FRENO - MASTER CYLINDERS Ø 25,4 - 1"

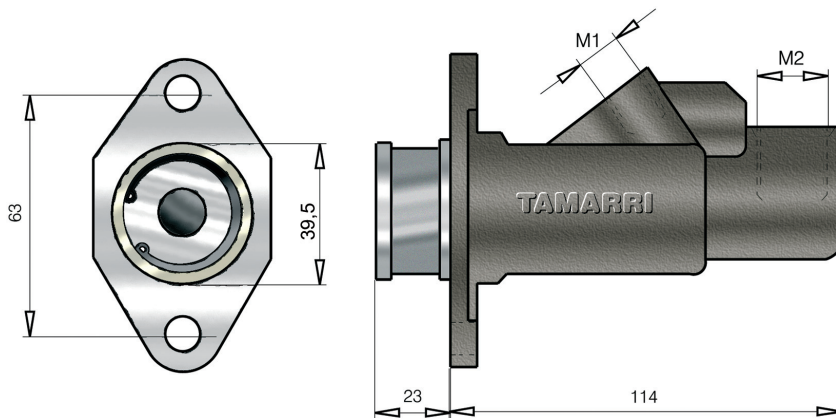

M1 14x1,5 	M2 14x1,5
M3	M4
Uscita Olio - Oil exit	

PF442M Olio minerale - Mineral oil Landini



I nostri ricambi non sono originali ma con essi perfettamente intercambiabili
 Our spare parts are not original but with them perfectly interchangeable



POMPE FRENO Ø 25,4 - 1"
MASTER CYLINDERS Ø 25,4 - 1"

**A
01**

POMPA FRENO - MASTER CYLINDERS Ø 25,4 - 1"

M1	M2
12x1.5 M	12x1 M
M3	M4
Uscita Olio - Oil exit	

PF204 Olio freni DOT3-4 - Brake oil DOT3-4 **PGS**

POMPA FRENO - MASTER CYLINDERS Ø 25,4 - 1"

M1	M2
7/16"20 fil. M	
M3	M4
Uscita Olio - Oil exit	

PF459 Olio freni DOT3-4 - Brake oil DOT3-4 **Yale**

POMPA FRENO - MASTER CYLINDERS Ø 25,4 - 1"

M1	M2
10x1 M	10x1 M
M3	M4
Uscita Olio - Oil exit	

PF463 Olio freni DOT3-4 - Brake oil DOT3-4 **OM-Still**



I nostri ricambi non sono originali ma con essi perfettamente intercambiabili
Our spare parts are not original but with them perfectly interchangeable



POMPE FRENO Ø 25,4 - 1"
MASTER CYLINDERS Ø 25,4 - 1"

**A
01**

POMPA FRENO - MASTER CYLINDERS Ø 25,4 - 1"

M1	M2
M3	M4
Uscita Olio - Oil exit	

PF227 Olio freni DOT3-4 - Brake oil DOT3-4 Toyota

POMPA FRENO - MASTER CYLINDERS Ø 25,4 - 1"

M1	M2
M3	M4
Uscita Olio - Oil exit	

PF111 Olio freni DOT3-4 - Brake oil DOT3-4 Jeep Spagnola

POMPA FRENO - MASTER CYLINDERS Ø 25,4 - 1"

M1	M2
M3	M4
Uscita Olio - Oil exit	

PF234 Olio freni DOT3-4 - Brake oil DOT3-4



I nostri ricambi non sono originali ma con essi perfettamente intercambiabili
 Our spare parts are not original but with them perfectly interchangeable



POMPE FRENO Ø 25,4 - 1"
MASTER CYLINDERS Ø 25,4 - 1"

**A
01**

POMPA FRENO - MASTER CYLINDERS Ø 25,4 - 1"		M1	M2
		M3	M4
PF240 Olio freni DOT3-4 - Brake oil DOT3-4 Hyster		Uscita Olio - Oil exit	

POMPA FRENO - MASTER CYLINDERS Ø 25,4 - 1"		M1	M2
		M3	M4
PF047 Olio freni DOT3-4 - Brake oil DOT3-4 Lancer Boss - Coventry Yale - Lansing B.		Uscita Olio - Oil exit	

POMPA FRENO - MASTER CYLINDERS Ø 25,4 - 1"		M1	M2
		M3	M4
PF072 Olio freni DOT3-4 - Brake oil DOT3-4 Toyota		Uscita Olio - Oil exit	



I nostri ricambi non sono originali ma con essi perfettamente intercambiabili
Our spare parts are not original but with them perfectly interchangeable



POMPE FRENO Ø 25,4 - 1"
MASTER CYLINDERS Ø 25,4 - 1"

**A
01**

POMPA FRENO - MASTER CYLINDERS Ø 25,4 - 1"		M1	M2
		7/16" 20 fil. 	3/8" 24 fil.
		M3 3/8" 24 fil. 	M4
		Uscita Olio - Oil exit 	
PF211	Olio freni DOT3-4 - Brake oil DOT3-4	Fenwick - Saxby - Matral	

POMPA FRENO - MASTER CYLINDERS Ø 25,4 - 1"		M1	M2
		14x1.5 	
		M3 	M4
		Uscita Olio - Oil exit 	
PF220	Olio freni DOT3-4 - Brake oil DOT3-4	Fenwick - Yale - Clark	

POMPA FRENO - MASTER CYLINDERS Ø 25,4 - 1"		M1	M2
		14x1.5 	
		M3 	M4
		Uscita Olio - Oil exit 	
PF062	Olio freni DOT3-4 - Brake oil DOT3-4	Yale	



I nostri ricambi non sono originali ma con essi perfettamente intercambiabili
Our spare parts are not original but with them perfectly interchangeable

A01

POMPE FRENO Ø 25,4 - 1"
MASTER CYLINDERS Ø 25,4 - 1"

**A
01**

POMPA FRENO - MASTER CYLINDERS Ø 25,4 - 1"

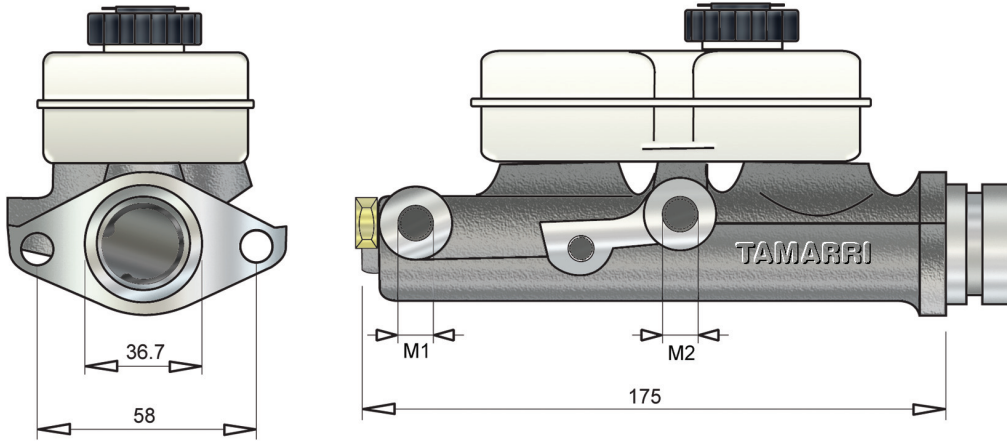

M1 10x1 	M2 10x1
M3	M4
Uscita Olio - Oil exit	

PF361 Olio freni DOT3-4 - Brake oil DOT3-4 Linde - Lansing - Still

POMPA FRENO - MASTER CYLINDERS Ø 25,4 - 1"

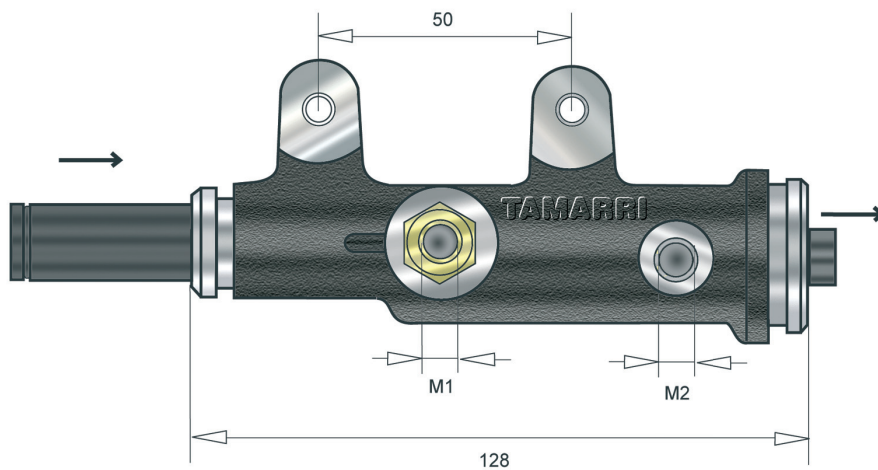

M1 12x1 	M2 12x1
M3	M4
Uscita Olio - Oil exit	

PF342 Olio minerale - Mineral oil Toyota - TCM

POMPA FRENO - MASTER CYLINDERS Ø 25,4 - 1"

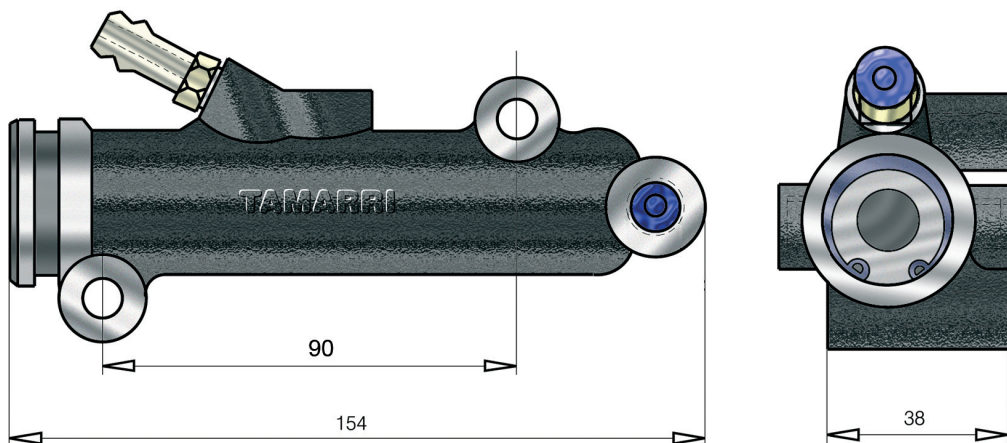

M1 10x1 	M2 10x1
M3	M4
Uscita Olio - Oil exit	

PF216 Olio freni DOT3-4 - Brake oil DOT3-4 Nissan



I nostri ricambi non sono originali ma con essi perfettamente intercambiabili
 Our spare parts are not original but with them perfectly interchangeable