

FRENI / BRAKES

A01

**POMPE FRENO Ø 28,57 - 1"1/8
MASTER CYLINDERS Ø 28,57 - 1"1/8**

**A
01**

| POMPA FRENO - MASTER CYLINDERS Ø 28,57 - 1"1/8 | | M1 | M2 |
|---|--------------------------------------|--------------------------------|-----------|
| | | | |
| | | M3 | M4 |
| | | Uscita Olio - Oil exit | |
| PF101/B | Olio freni DOT3-4 - Brake oil DOT3-4 | Clark - Caterpillar - Towmotor | |

| POMPA FRENO - MASTER CYLINDERS Ø 28,57 - 1"1/8 | | M1 | M2 |
|---|--------------------------------------|-------------------------------|-----------|
| | | | |
| | | M3 | M4 |
| | | Uscita Olio - Oil exit | |
| PF102/A | Olio freni DOT3-4 - Brake oil DOT3-4 | Clark - Hyster | |

| POMPA FRENO - MASTER CYLINDERS Ø 28,57 - 1"1/8 | | M1 | M2 |
|---|--------------------------------------|-------------------------------|-----------|
| | | | |
| | | M3 | M4 |
| | | Uscita Olio - Oil exit | |
| | | | |
| PF210 | Olio freni DOT3-4 - Brake oil DOT3-4 | Manitou - Fenwick | |



I nostri ricambi non sono originali ma con essi perfettamente intercambiabili
Our spare parts are not original but with them perfectly interchangeable

FRENI / BRAKES

A01

**POMPE FRENO Ø 28,57 - 1"1/8
MASTER CYLINDERS Ø 28,57 - 1"1/8**

**A
01**

POMPA FRENO - MASTER CYLINDERS Ø 28,57 - 1"1/8

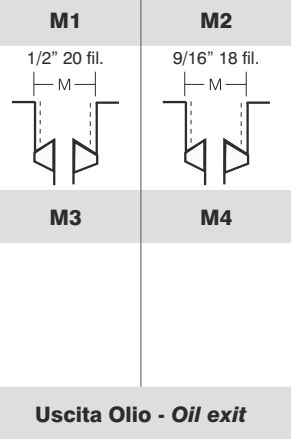
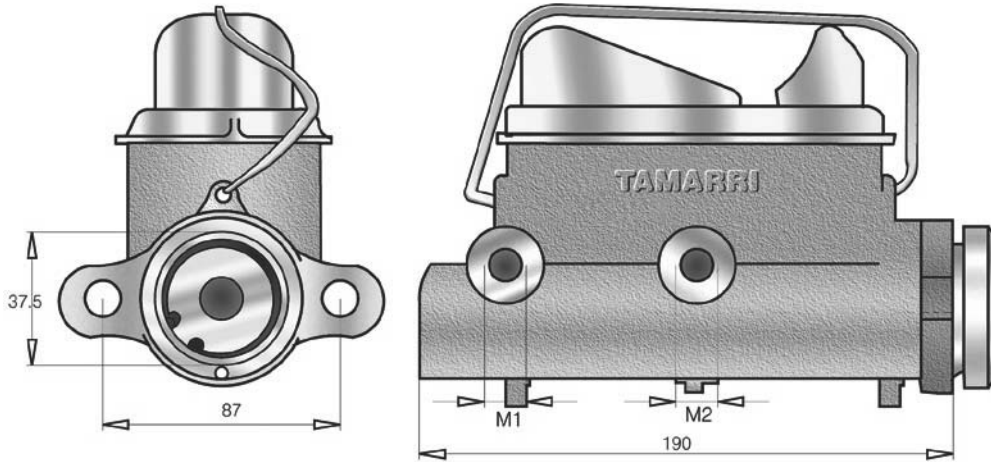

PF026 Olio freni DOT3-4 - Brake oil DOT3-4 Greder

POMPA FRENO - MASTER CYLINDERS Ø 28,57 - 1"1/8

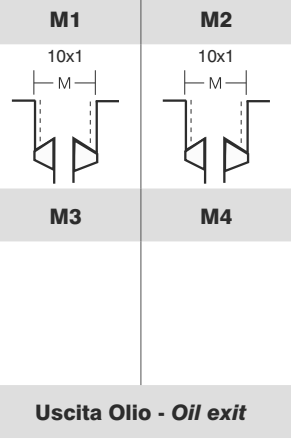
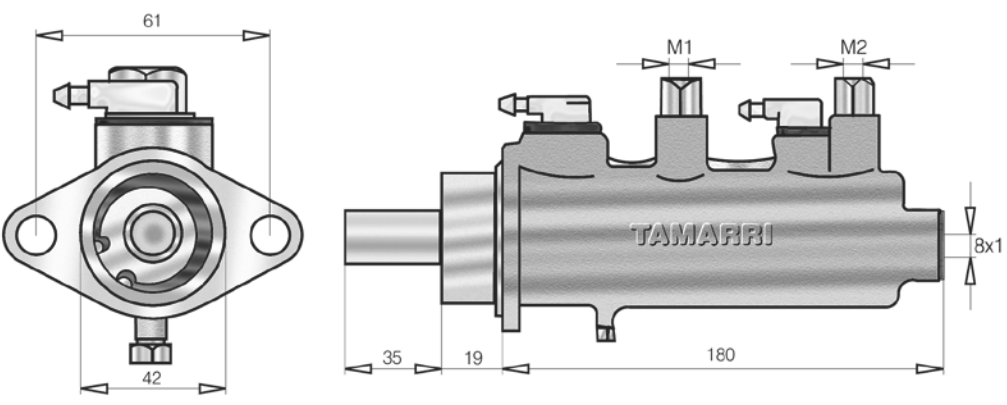

PF043 Olio freni DOT3-4 - Brake oil DOT3-4 Ursus

POMPA FRENO - MASTER CYLINDERS Ø 28,57 - 1"1/8

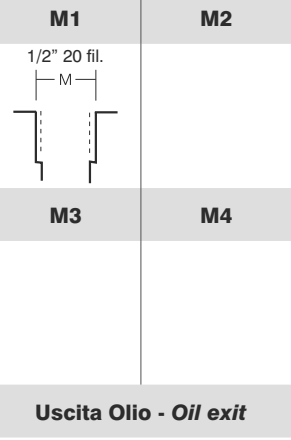
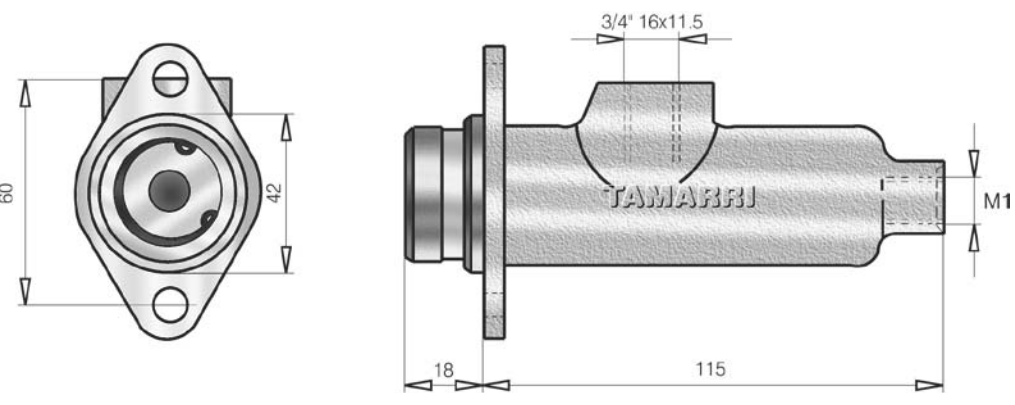

PF048 Olio freni DOT3-4 - Brake oil DOT3-4 Salev



I nostri ricambi non sono originali ma con essi perfettamente intercambiabili
Our spare parts are not original but with them perfectly interchangeable

FRENI / BRAKES

A01

**POMPE FRENO Ø 28,57 - 1"1/8
MASTER CYLINDERS Ø 28,57 - 1"1/8**

**A
01**

POMPA FRENO - MASTER CYLINDERS Ø 28,57 - 1"1/8

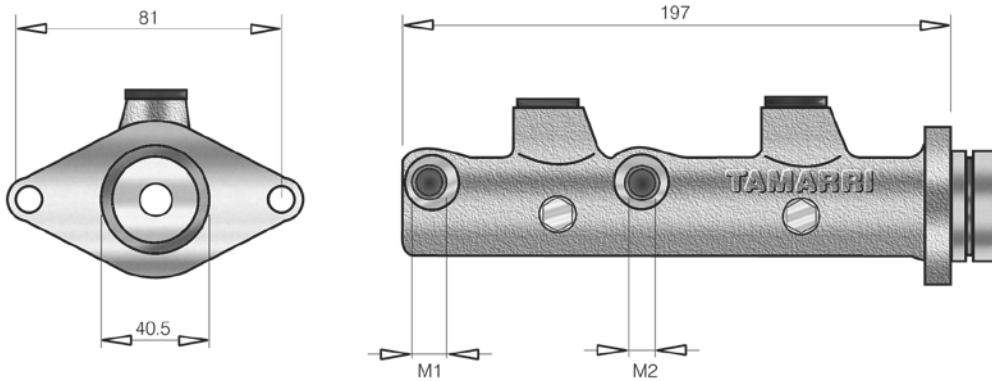

| | |
|-------------------------------|-----------|
| M1 | M2 |
| 10x1 M | 10x1 M |
| M3 | M4 |
| Uscita Olio - Oil exit | |

PF292 Olio freni DOT3-4 - Brake oil DOT3-4

POMPA FRENO - MASTER CYLINDERS Ø 28,57 - 1"1/8

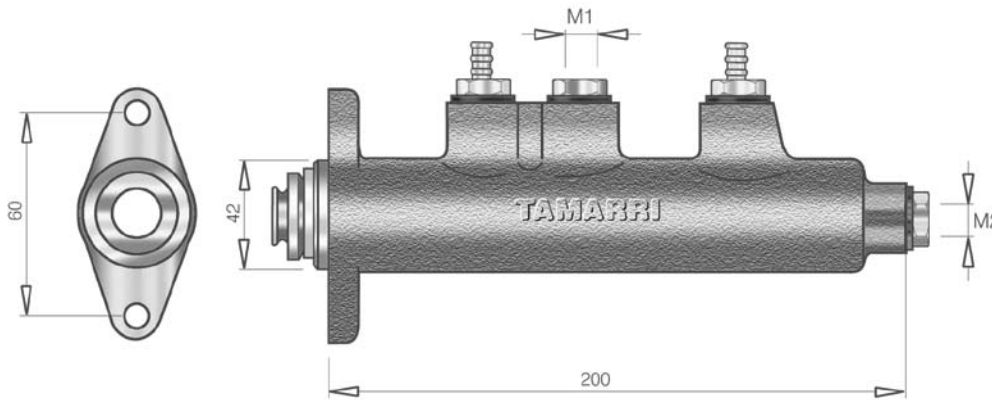

| | |
|-------------------------------|-----------|
| M1 | M2 |
| 12x1 M | 12x1 M |
| M3 | M4 |
| Uscita Olio - Oil exit | |

PF325 Olio freni DOT3-4 - Brake oil DOT3-4 **Fresia**

POMPA FRENO - MASTER CYLINDERS Ø 28,57 - 1"1/8

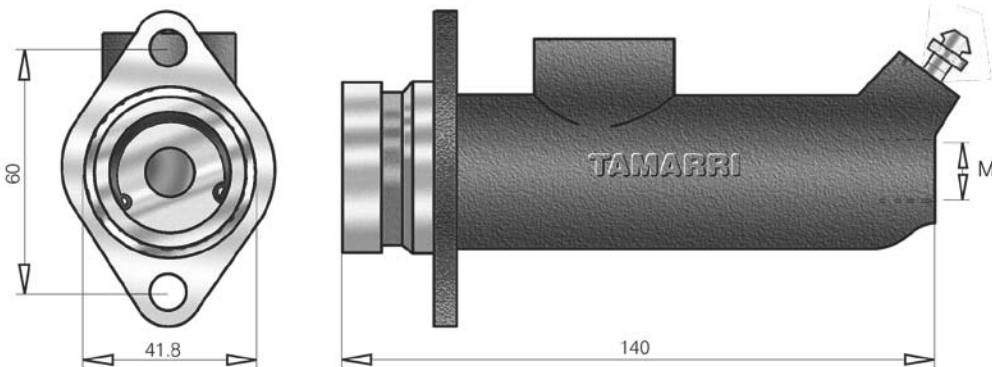

| | |
|-------------------------------|-----------|
| M1 | M2 |
| 1/2" 20 fil. M | |
| M3 | M4 |
| Uscita Olio - Oil exit | |

PF336M Solo olio minerale - Mineral oil only **Manitou**



I nostri ricambi non sono originali ma con essi perfettamente intercambiabili
Our spare parts are not original but with them perfectly interchangeable

FRENI / BRAKES

A01

**POMPE FRENO Ø 28,57 - 1"1/8
MASTER CYLINDERS Ø 28,57 - 1"1/8**

**A
01**

| POMPA FRENO - MASTER CYLINDERS Ø 28,57 - 1"1/8 | | M1 | M2 |
|--|-----------------------------|-------------------------------|----|
| | | | |
| | | | |
| | | Uscita Olio - Oil exit | |
| PF366M | Olio minerale - Mineral oil | JCB | |

| POMPA FRENO - MASTER CYLINDERS Ø 28,57 - 1"1/8 | | M1 | M2 |
|--|--------------------------------------|-------------------------------|----|
| | | | |
| | | | |
| | | Uscita Olio - Oil exit | |
| PF368 | Olio freni DOT3-4 - Brake oil DOT3-4 | Komatsu | |

| POMPA FRENO - MASTER CYLINDERS Ø 28,57 - 1"1/8 | | M1 | M2 |
|--|----|-------------------------------|----|
| | | | |
| | | | |
| | | Uscita Olio - Oil exit | |
| PF376 | DX | Mitsubishi | |



I nostri ricambi non sono originali ma con essi perfettamente intercambiabili
Our spare parts are not original but with them perfectly interchangeable

FRENI / BRAKES

A01

**POMPE FRENO Ø 28,57 - 1"1/8
MASTER CYLINDERS Ø 28,57 - 1"1/8**

**A
01**

POMPA FRENO - MASTER CYLINDERS Ø 28,57 - 1"1/8

| | |
|-------------------------------|-----------|
| M1 | M2 |
| 10x1 M | 10x1 M |
| M3 | M4 |
| Uscita Olio - Oil exit | |
| | |

PF378 SX Mitsubishi

POMPA FRENO - MASTER CYLINDERS Ø 28,57 - 1"1/8

| | |
|-------------------------------|-------------|
| M1 | M2 |
| 1/2" 20FIL M | 1/8BSP M |
| M3 | M4 |
| 3/8"NPT M | |
| Uscita Olio - Oil exit | |
| | |

PF398 Olio freni DOT3-4 - Brake oil DOT3-4 Daewoo

POMPA FRENO - MASTER CYLINDERS Ø 28,57 - 1"1/8

| | |
|-------------------------------|-----------|
| M1 | M2 |
| 10x1 M | 10x1 M |
| M3 | M4 |
| Uscita Olio - Oil exit | |

PF468 Olio freni DOT3-4 - Brake oil DOT3-4 HANGCHA



I nostri ricambi non sono originali ma con essi perfettamente intercambiabili
Our spare parts are not original but with them perfectly interchangeable