

**FRENI / BRAKES**

**A01**

**POMPE FRENO Ø 31,75 - 1"1/4  
MASTER CYLINDERS Ø 31,75 - 1"1/4**

**A  
01**

POMPA FRENO - MASTER CYLINDERS Ø 31,75 - 1"1/4		M1	M2
		M3	M4
		Uscita Olio - Oil exit	
PF101/E	Olío freni DOT3-4 - Brake oil DOT3-4	Caterpillar	

POMPA FRENO - MASTER CYLINDERS Ø 31,75 - 1"1/4		M1	M2
		M3	M4
		Uscita Olio - Oil exit	
PF015	Olío freni DOT3-4 - Brake oil DOT3-4		

POMPA FRENO - MASTER CYLINDERS Ø 31,75 - 1"1/4		M1	M2
		M3	M4
		Uscita Olio - Oil exit	
PF304	Olío freni DOT3-4 - Brake oil DOT3-4	Cesab	



I nostri ricambi non sono originali ma con essi perfettamente intercambiabili  
Our spare parts are not original but with them perfectly interchangeable

**FRENI / BRAKES**

**A01**

**POMPE FRENO Ø 31,75 - 1"1/4  
MASTER CYLINDERS Ø 31,75 - 1"1/4**

**A  
01**

<b>POMPA FRENO - MASTER CYLINDERS</b> Ø 31,75 - 1"1/4		<b>M1</b>	<b>M2</b>
		<b>M3</b>	<b>M4</b>
		<b>Uscita Olio - Oil exit</b>	
<b>PF304/A</b>	Olio freni DOT3-4 - Brake oil DOT3-4	OM	

<b>POMPA FRENO - MASTER CYLINDERS</b> Ø 31,75 - 1"1/4		<b>M1</b>	<b>M2</b>
		<b>M3</b>	<b>M4</b>
		<b>Uscita Olio - Oil exit</b>	
<b>PF018</b>	Olio freni DOT3-4 - Brake oil DOT3-4	Venieri	

<b>POMPA FRENO - MASTER CYLINDERS</b> Ø 31,75 - 1"1/4		<b>M1</b>	<b>M2</b>
		<b>M3</b>	<b>M4</b>
		<b>Uscita Olio - Oil exit</b>	
<b>PF046</b>	Olio freni DOT3-4 - Brake oil DOT3-4	OM	



I nostri ricambi non sono originali ma con essi perfettamente intercambiabili  
Our spare parts are not original but with them perfectly interchangeable

**FRENI / BRAKES**

**A01**

**POMPE FRENO Ø 31,75 - 1"1/4  
MASTER CYLINDERS Ø 31,75 - 1"1/4**

**A  
01**

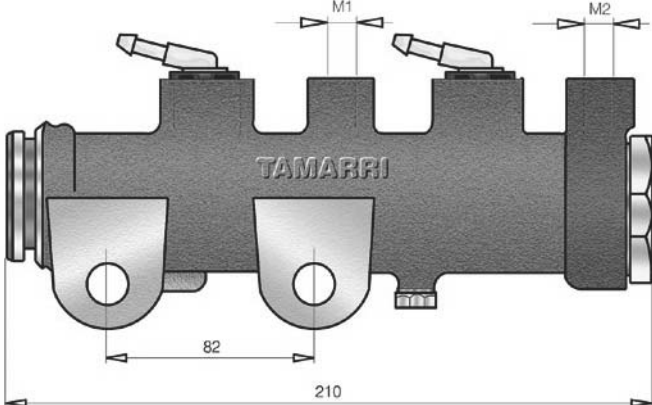
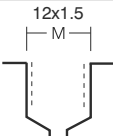
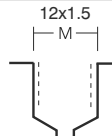
<b>POMPA FRENO - MASTER CYLINDERS</b> Ø 31,75 - 1"1/4		<b>M1</b>	<b>M2</b>
			
		<b>M3</b>	<b>M4</b>
		<b>Uscita Olio - Oil exit</b>	
<b>PF294</b>	Olío freni DOT3-4 - Brake oil DOT3-4		
<b>PF294M</b>	Solo olío minerale - Mineral oil only	Fantuzzi	

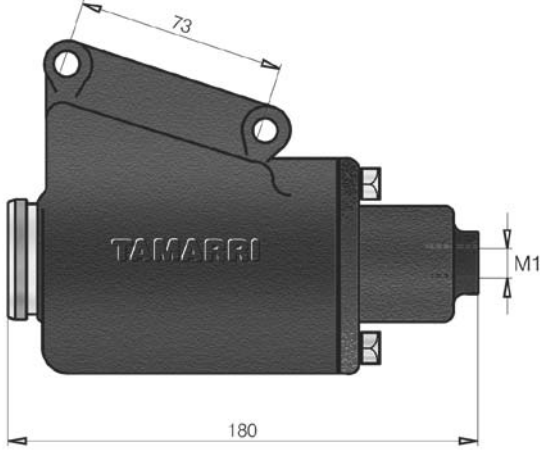
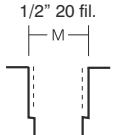
<b>POMPA FRENO - MASTER CYLINDERS</b> Ø 31,75 - 1"1/4		<b>M1</b>	<b>M2</b>
			
		<b>M3</b>	<b>M4</b>
		<b>Uscita Olio - Oil exit</b>	
<b>PF241</b>	Olío freni DOT3-4 - Brake oil DOT3-4	Clark - Baker	

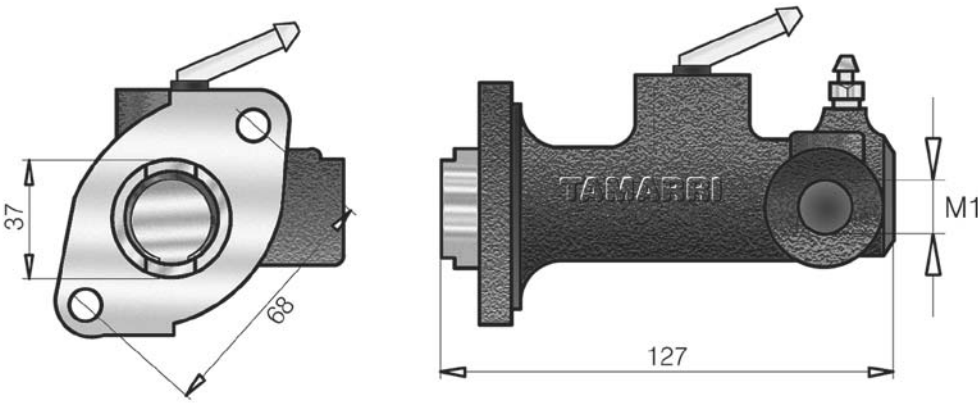
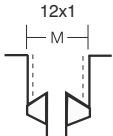
<b>POMPA FRENO - MASTER CYLINDERS</b> Ø 31,75 - 1"1/4		<b>M1</b>	<b>M2</b>
			
		<b>M3</b>	<b>M4</b>
		<b>Uscita Olio - Oil exit</b>	
<b>PF317/A</b>	Olío freni DOT3-4 - Brake oil DOT3-4	Clark	



I nostri ricambi non sono originali ma con essi perfettamente intercambiabili  
Our spare parts are not original but with them perfectly interchangeable

**FRENI / BRAKES**

**A01**

**POMPE FRENO Ø 31,75 - 1"1/4  
MASTER CYLINDERS Ø 31,75 - 1"1/4**

**A  
01**

POMPA FRENO - MASTER CYLINDERS Ø 31,75 - 1"1/4		M1	M2
		M3	M4
<b>Uscita Olio - Oil exit</b>			
<b>PF104/A</b>	Olío freni DOT3-4 - Brake oil DOT3-4		Ticino

POMPA FRENO - MASTER CYLINDERS Ø 31,75 - 1"1/4		M1	M2
		M3	M4
<b>Uscita Olio - Oil exit</b>			
<b>PF341M</b>	Olío minerale - Mineral oil		
<b>PF092</b>	Olío freni DOT3-4 - Brake oil DOT3-4		

POMPA FRENO - MASTER CYLINDERS Ø 31,75 - 1"1/4		M1	M2
		M3	M4
<b>Uscita Olio - Oil exit</b>			
<b>PF104</b>	Olío freni DOT3-4 - Brake oil DOT3-4		Caterpillar - Clark - Hyster - Fiat Allis



I nostri ricambi non sono originali ma con essi perfettamente intercambiabili  
Our spare parts are not original but with them perfectly interchangeable

**FRENI / BRAKES**

**A01**

**POMPE FRENO Ø 31,75 - 1"1/4  
MASTER CYLINDERS Ø 31,75 - 1"1/4**

**A  
01**

<b>POMPA FRENO - MASTER CYLINDERS</b> Ø 31,75 - 1"1/4		<b>M1</b>	<b>M2</b>
		<b>M3</b>	<b>M4</b>
		<b>Uscita Olio - Oil exit</b>	
<b>PF106</b>	Olio freni DOT3-4 - Brake oil DOT3-4		Caterpillar

<b>POMPA FRENO - MASTER CYLINDERS</b> Ø 31,75 - 1"1/4		<b>M1</b>	<b>M2</b>
		<b>M3</b>	<b>M4</b>
		<b>Uscita Olio - Oil exit</b>	
<b>PF107</b>	Olio freni DOT3-4 - Brake oil DOT3-4		Caterpillar

<b>POMPA FRENO - MASTER CYLINDERS</b> Ø 31,75 - 1"1/4		<b>M1</b>	<b>M2</b>
		<b>M3</b>	<b>M4</b>
		<b>Uscita Olio - Oil exit</b>	
<b>PF010</b>	Olio freni DOT3-4 - Brake oil DOT3-4		Bendini - Unimog



I nostri ricambi non sono originali ma con essi perfettamente intercambiabili  
Our spare parts are not original but with them perfectly interchangeable

**FRENI / BRAKES**

**A01**

**POMPE FRENO Ø 31,75 - 1"1/4  
MASTER CYLINDERS Ø 31,75 - 1"1/4**

**A  
01**

POMPA FRENO - MASTER CYLINDERS Ø 31,75 - 1"1/4		M1	M2
		M3	M4
		<b>Uscita Olio - Oil exit</b>	
<b>PF010/A</b>	Olío freni DOT3-4 - Brake oil DOT3-4	Kalmar	

POMPA FRENO - MASTER CYLINDERS Ø 31,75 - 1"1/4		M1	M2
		M3	M4
		<b>Uscita Olio - Oil exit</b>	
<b>PF010/AM</b>	Solo olío minerale - Mineral oil only	Fiat Allis	

POMPA FRENO - MASTER CYLINDERS Ø 31,75 - 1"1/4		M3
		<b>M1-M2- M4 - M5</b>
		<b>Uscita Olio - Oil exit</b>
<b>PF020</b>	Olío freni DOT3-4 - Brake oil DOT3-4	



I nostri ricambi non sono originali ma con essi perfettamente intercambiabili  
Our spare parts are not original but with them perfectly interchangeable

**FRENI / BRAKES**

**A01**

**POMPE FRENO Ø 31,75 - 1"1/4  
MASTER CYLINDERS Ø 31,75 - 1"1/4**

**A  
01**

POMPA FRENO - MASTER CYLINDERS Ø 31,75 - 1"1/4		M1	M2
		M3	M4
		Uscita Olio - Oil exit	
<b>PF020/A</b>	Olio freni DOT3-4 - Brake oil DOT3-4	Unimog	

POMPA FRENO - MASTER CYLINDERS Ø 31,75 - 1"1/4		M1	M2
		M3	M4
		Uscita Olio - Oil exit	
<b>PF021</b>	Olio freni DOT3-4 - Brake oil DOT3-4	O & K	

POMPA FRENO - MASTER CYLINDERS Ø 31,75 - 1"1/4		M1	M2
		M3	M4
		Uscita Olio - Oil exit	
<b>PF028</b>	Olio freni DOT3-4 - Brake oil DOT3-4		



I nostri ricambi non sono originali ma con essi perfettamente intercambiabili  
Our spare parts are not original but with them perfectly interchangeable

**FRENI / BRAKES**

**A01**

**POMPE FRENO Ø 31,75 - 1"1/4  
MASTER CYLINDERS Ø 31,75 - 1"1/4**

**A  
01**

**POMPA FRENO - MASTER CYLINDERS** Ø 31,75 - 1"1/4

M1	M2
1/2" 20 fil. 	9/16" 18 fil. 
M3	M4
<b>Uscita Olio - Oil exit</b>	

<b>PF320</b>	Olío freni DOT3-4 - <i>Brake oil DOT3-4</i>	Greder
<b>PF320M</b>	Solo olío minerale - <i>Mineral oil only</i>	Greder

**POMPA FRENO - MASTER CYLINDERS** Ø 31,75 - 1"1/4

M1	M2
14x1.5 	
M3	M4
<b>Uscita Olio - Oil exit</b>	

<b>PF220/A</b>	Olío freni DOT3-4 - <i>Brake oil DOT3-4</i>	
----------------	---	--

**POMPA FRENO - MASTER CYLINDERS** Ø 31,75 - 1"1/4

M1	M2
12x1.25 	
M3	M4
<b>Uscita Olio - Oil exit</b>	

<b>PF033</b>	Olío freni DOT3-4 - <i>Brake oil DOT3-4</i>	Ticino
--------------	---	--------



I nostri ricambi non sono originali ma con essi perfettamente intercambiabili  
Our spare parts are not original but with them perfectly interchangeable



**FRENI / BRAKES**

**A01**

**POMPE FRENO Ø 31,75 - 1"1/4  
MASTER CYLINDERS Ø 31,75 - 1"1/4**

**A  
01**

**POMPA FRENO - MASTER CYLINDERS** Ø 31,75 - 1"1/4

<b>M1</b>	<b>M2</b>
16x1.5 M	
<b>M3</b>	<b>M4</b>
<b>Uscita Olio - Oil exit</b>	

**PF305/A** Olio freni DOT3-4 - Brake oil DOT3-4 OM

**POMPA FRENO - MASTER CYLINDERS** Ø 31,75 - 1"1/4

<b>M1</b>	<b>M2</b>
16x1.5 M	
<b>M3</b>	<b>M4</b>
<b>Uscita Olio - Oil exit</b>	

**PF305/AM** Solo olio minerale - Mineral oil only MANITOU

**POMPA FRENO - MASTER CYLINDERS** Ø 31,75 - 1"1/4

<b>M1</b>	<b>M2</b>
14x1.5 M	
<b>M3</b>	<b>M4</b>
<b>Uscita Olio - Oil exit</b>	

**PF255** Olio freni DOT3-4 - Brake oil DOT3-4 Ormic



I nostri ricambi non sono originali ma con essi perfettamente intercambiabili  
Our spare parts are not original but with them perfectly interchangeable

**FRENI / BRAKES**

**A01**

**POMPE FRENO Ø 31,75 - 1"1/4  
MASTER CYLINDERS Ø 31,75 - 1"1/4**

**A  
01**

**POMPA FRENO - MASTER CYLINDERS** Ø 31,75 - 1"1/4

M1	M2
7/16" 20 fil. 	3/8" 24 fil. 
M3	M4
<b>Uscita Olio - Oil exit</b>	

**PF265** Olio freni DOT3-4 - Brake oil DOT3-4 Lancer Boss

**POMPA FRENO - MASTER CYLINDERS** Ø 31,75 - 1"1/4

M1	M2
10x1 	10x1 
M3	M4
1/8" GAS 	
<b>Uscita Olio - Oil exit</b>	

**PF274** Olio freni DOT3-4 - Brake oil DOT3-4 Mitsubishi

**POMPA FRENO - MASTER CYLINDERS** Ø 31,75 - 1"1/4

M1	M2
12x1.5 	
M3	M4
<b>Uscita Olio - Oil exit</b>	

**PF278** Olio freni DOT3-4 - Brake oil DOT3-4 TCM



I nostri ricambi non sono originali ma con essi perfettamente intercambiabili  
Our spare parts are not original but with them perfectly interchangeable



**POMPE FRENO Ø 31,75 - 1"1/4**  
**MASTER CYLINDERS Ø 31,75 - 1"1/4**

A  
01

POMPA FRENO - MASTER CYLINDERS Ø 31,75 - 1"1/4		M1	M2
		M3	M4
		Uscita Olio - Oil exit	
<b>PF358M</b>	Olio minerale - Mineral oil		
<b>PF291</b>	Olio freno DOT3-4 - Brake fluid DOT3-4		

POMPA FRENO - MASTER CYLINDERS Ø 31,75 - 1"1/4		M1	M2
		M3	M4
		Uscita Olio - Oil exit	
<b>PF323</b>	Olio freni DOT3-4 - Brake oil DOT3-4		
	Fiat Allis - Caterpillar		

POMPA FRENO - MASTER CYLINDERS Ø 31,75 - 1"1/4		M1	M2
		M3	M4
		Uscita Olio - Oil exit	
<b>PF330</b>	Olio freni DOT3-4 - Brake oil DOT3-4		
	Hanomag		





**POMPE FRENO Ø 31,75 - 1"1/4**  
**MASTER CYLINDERS Ø 31,75 - 1"1/4**

A  
01

POMPA FRENO - MASTER CYLINDERS Ø 31,75 - 1"1/4		M1	M2
		M3	M4
		<b>Uscita Olio - Oil exit</b>	
<b>PF349</b>	Olio freni DOT3-4 - Brake oil DOT3-4		Hanley

POMPA FRENO - MASTER CYLINDERS Ø 31,75 - 1"1/4		M1	M2
		M3	M4
		<b>Uscita Olio - Oil exit</b>	
<b>PF350</b>	Con staffa - With bracket		

POMPA FRENO - MASTER CYLINDERS Ø 31,75 - 1"1/4		M1	M2
		M3	M4
		<b>Uscita Olio - Oil exit</b>	
<b>PF352</b>	Olio freni DOT3-4 - Brake oil DOT3-4		Militare



I nostri ricambi non sono originali ma con essi perfettamente intercambiabili  
 Our spare parts are not original but with them perfectly interchangeable



**POMPE FRENO Ø 31,75 - 1"1/4**  
**MASTER CYLINDERS Ø 31,75 - 1"1/4**

A  
01

POMPA FRENO - MASTER CYLINDERS Ø 31,75 - 1"1/4		M1	M2
		M3	M4
		Uscita Olio - Oil exit	
<b>PF370</b>	Olio freni DOT3-4 - Brake oil DOT3-4		

POMPA FRENO - MASTER CYLINDERS Ø 31,75 - 1"1/4		M1	M2
		M3	M4
		Uscita Olio - Oil exit	
<b>PF413</b>	Olio freni DOT3-4 - Brake oil DOT3-4		Motospazzatrice

POMPA FRENO - MASTER CYLINDERS Ø 31,75 - 1"1/4		M1	M2
		M3	M4
		Uscita Olio - Oil exit	
<b>PF006</b>	Olio freni DOT3-4 - Brake oil DOT3-4		Jungheinrich



**FRENI / BRAKES**

**A01**

**POMPE FRENO Ø 31,75 - 1"1/4  
MASTER CYLINDERS Ø 31,75 - 1"1/4**

**A  
01**

**POMPA FRENO - MASTER CYLINDERS** Ø 31,75 - 1"1/4

<b>M1</b>	<b>M2</b>
1/2"20FI M	
<b>M3</b>	<b>M4</b>
<b>Uscita Olio - Oil exit</b>	

**PF444M**    Olio minerale - Mineral oil    Manitou

**POMPA FRENO - MASTER CYLINDERS** Ø 31,75 - 1"1/4

<b>M1</b>	<b>M2</b>
12x1 M	
<b>M3</b>	<b>M4</b>
<b>Uscita Olio - Oil exit</b>	

**PF042**    Olio freni DOT3-4 - Brake oil DOT3-4    Toyota