

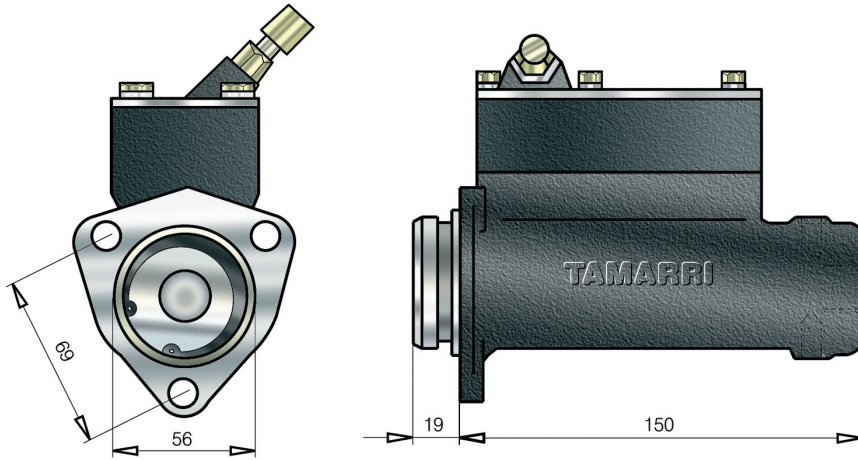

**POMPE FRENO Ø 38,1 - 1"1/2**  
**MASTER CYLINDERS Ø 38,1 - 1"1/2**

**A  
01**

**POMPA FRENO - MASTER CYLINDERS** Ø 38,1 - 1"1/2



|                               |                           |
|-------------------------------|---------------------------|
| <b>M1</b><br>1/2" 20 fil.<br> | <b>M2</b><br>1/8" GAS<br> |
| <b>M3</b><br>5/8" GAS<br>     | <b>M4</b>                 |
| <b>Uscita Olio - Oil exit</b> |                           |
|                               |                           |

**PF014** Olio freni DOT3-4 - Brake oil DOT3-4

**POMPA FRENO - MASTER CYLINDERS** Ø 38,1 - 1"1/2

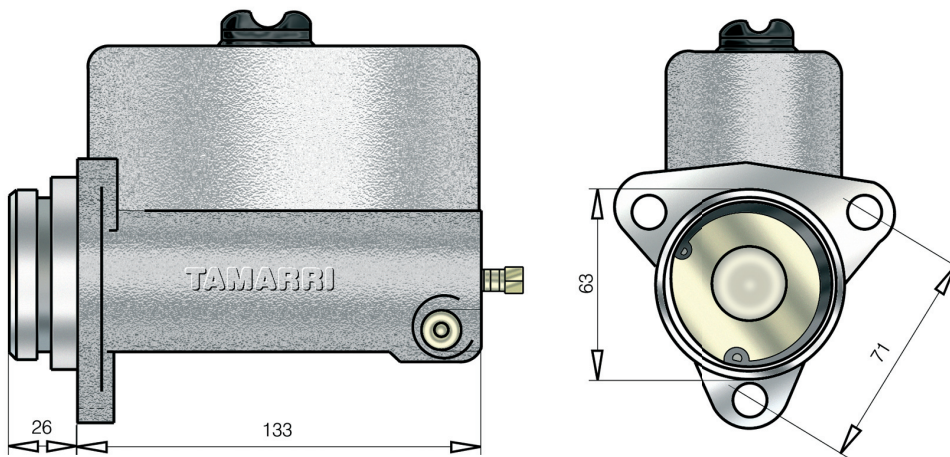

|                               |                               |
|-------------------------------|-------------------------------|
| <b>M1</b><br>1/2" 20 fil.<br> | <b>M2</b><br>1/2" 20 fil.<br> |
| <b>M3</b>                     | <b>M4</b>                     |
| <b>Uscita Olio - Oil exit</b> |                               |
|                               |                               |

**PF013** Olio freni DOT3-4 - Brake oil DOT3-4 Fiat Allis - Clark - Caterpillar

**POMPA FRENO - MASTER CYLINDERS** Ø 38,1 - 1"1/2

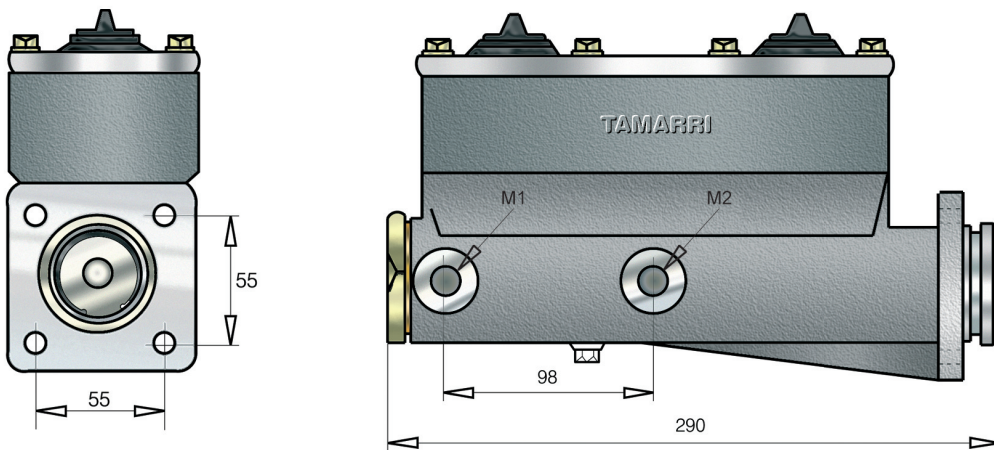

|                               |                       |
|-------------------------------|-----------------------|
| <b>M1</b><br>12x1<br>         | <b>M2</b><br>12x1<br> |
| <b>M3</b>                     | <b>M4</b>             |
| <b>Uscita Olio - Oil exit</b> |                       |

**PF011** Olio freni DOT3-4 - Brake oil DOT3-4 Ormic





**POMPE FRENO Ø 38,1 - 1"1/2**  
**MASTER CYLINDERS Ø 38,1 - 1"1/2**

**A  
01**

| POMPA FRENO - MASTER CYLINDERS Ø 38,1 - 1"1/2 |   | M1                     | M2 |
|---|---|------------------------|----|
|   |   |                        |    |
|   |   | M3                     | M4 |
|   |   | Uscita Olio - Oil exit |    |
| PF101/F                                       | Olio freni DOT3-4 - Brake oil DOT3-4<br>Fiat Allis - Caterpillar - Hyster |                        |    |

| POMPA FRENO - MASTER CYLINDERS Ø 38,1 - 1"1/2 |   | M1                     | M2 |
|---|---|------------------------|----|
|   |   |                        |    |
|   |   | M3                     | M4 |
|   |   | Uscita Olio - Oil exit |    |
| PF239   | Olio freni DOT3-4 - Brake oil DOT3-4<br>Sambrom |                        |    |

| POMPA FRENO - MASTER CYLINDERS Ø 38,1 - 1"1/2 |   | M1                     | M2 |
|---|---|------------------------|----|
|   |   |                        |    |
|   |   | M3                     | M4 |
|   |   | Uscita Olio - Oil exit |    |
| PF347M  | Olio minerale - Mineral oil                     |                        |    |
| PF296   | Olio freni DOT3-4 - Brake oil DOT3-4<br>Sambrom |                        |    |

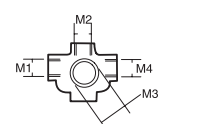

I nostri ricambi non sono originali ma con essi perfettamente intercambiabili  
 Our spare parts are not original but with them perfectly interchangeable



**POMPE FRENO Ø 38,1 - 1"1/2**  
**MASTER CYLINDERS Ø 38,1 - 1"1/2**

**A  
01**

| POMPA FRENO - MASTER CYLINDERS Ø 38,1 - 1"1/2 |                                       | M1                     | M2 |
|---|---------------------------------------|------------------------|----|
|   |                                       |                        | M3 |
|   |                                       |                        | M4 |
|   |                                       | Uscita Olio - Oil exit |    |
| PF010/BM                                      | Solo olio minerale - Mineral oil only |                        |    |
| PF010/B                                       | Olio freni DOT3-4 - Brake oil DOT3-4  |                        |    |

| POMPA FRENO - MASTER CYLINDERS Ø 38,1 - 1"1/2 |                                      | M1                                       | M2 |
|---|--------------------------------------|--|----|
|   |                                      |  | M3 |
|   |                                      |  | M4 |
|   |                                      | Uscita Olio - Oil exit                   |    |
| PF022   | Olio freni DOT3-4 - Brake oil DOT3-4 | Bationi & Pagani - Benati<br>F.lli Dieci |    |

| POMPA FRENO - MASTER CYLINDERS Ø 38,1 - 1"1/2 |                                      | M1                     | M2 |
|---|--------------------------------------|------------------------|----|
|   |                                      |                        | M3 |
|   |                                      |                        | M4 |
|   |                                      | Uscita Olio - Oil exit |    |
|   |                                      |                        |    |
| PF035   | Olio freni DOT3-4 - Brake oil DOT3-4 | O & K                  |    |





**POMPE FRENO Ø 38,1 - 1"1/2**  
**MASTER CYLINDERS Ø 38,1 - 1"1/2**

**A  
01**

| POMPA FRENO - MASTER CYLINDERS Ø 38,1 - 1"1/2 |   | M1                                   | M2 |
|---|---|--------------------------------------|----|
|   | <p><b>PF064</b> Olio freni DOT3-4 - Brake oil DOT3-4</p> <p>Lancer Boss</p> |                                      |    |
|   |   | <p><b>Uscita Olio - Oil exit</b></p> |    |

| POMPA FRENO - MASTER CYLINDERS Ø 38,1 - 1"1/2 |   | M1                                   | M2 |
|---|---|--------------------------------------|----|
|   | <p><b>PF065M</b> Solo olio minerale - Mineral oil only</p> <p><b>PF110</b> Olio freni DOT3-4 - Brake oil DOT3-4</p> <p>Anomag</p> |                                      |    |
|   |   | <p><b>Uscita Olio - Oil exit</b></p> |    |

| POMPA FRENO - MASTER CYLINDERS Ø 38,1 - 1"1/2 |   | M1                                   | M2 |
|---|---|--------------------------------------|----|
|   | <p><b>PF109</b> Olio freni DOT3-4 - Brake oil DOT3-4</p> <p>Venieri</p> |                                      |    |
|   |   | <p><b>Uscita Olio - Oil exit</b></p> |    |



I nostri ricambi non sono originali ma con essi perfettamente intercambiabili  
 Our spare parts are not original but with them perfectly interchangeable



**POMPE FRENO Ø 38,1 - 1"1/2**  
**MASTER CYLINDERS Ø 38,1 - 1"1/2**

A  
01

**POMPA FRENO - MASTER CYLINDERS** Ø 38,1 - 1"1/2

| M1                            | M2 |
|-------------------------------|----|
| 12x1.25<br>M                  |    |
| M3                            | M4 |
|                               |    |
| <b>Uscita Olio - Oil exit</b> |    |
|                               |    |

**PF108** Olio freni DOT3-4 - Brake oil DOT3-4

**POMPA FRENO - MASTER CYLINDERS** Ø 38,1 - 1"1/2

| M1                            | M2                |
|-------------------------------|-------------------|
| 1/2" 20 fil.<br>M             | 1/2" 20 fil.<br>M |
| M3                            | M4                |
|                               |                   |
| <b>Uscita Olio - Oil exit</b> |                   |
|                               |                   |

**PF282** Olio freni DOT3-4 - Brake oil DOT3-4 Halla

**POMPA FRENO - MASTER CYLINDERS** Ø 38,1 - 1"1/2

| M1                            | M2        |
|-------------------------------|-----------|
| 12x1<br>M                     | 12x1<br>M |
| M3                            | M4        |
|                               |           |
| <b>Uscita Olio - Oil exit</b> |           |
|                               |           |

**PF328M** Solo olio minerale - Mineral oil only JCB



I nostri ricambi non sono originali ma con essi perfettamente intercambiabili  
 Our spare parts are not original but with them perfectly interchangeable



**POMPE FRENO Ø 38,1 - 1"1/2**  
**MASTER CYLINDERS Ø 38,1 - 1"1/2**

**A  
01**

| POMPA FRENO - MASTER CYLINDERS Ø 38,1 - 1"1/2 |                                       | M1    | M2 |
|---|---------------------------------------|-------|----|
|   |                                       |       |    |
|   |                                       |       |    |
| <b>PF399M</b>                                 | Solo olio minerale - Mineral oil only | Terex |    |

| POMPA FRENO - MASTER CYLINDERS Ø 38,1 - 1"1/2 |                                      | M1  | M2 |
|---|--------------------------------------|-----|----|
|   |                                      |     |    |
|   |                                      |     |    |
| <b>PF338</b>                                  | Olio freni DOT3-4 - Brake oil DOT3-4 | TCM |    |

| POMPA FRENO - MASTER CYLINDERS Ø 38,1 - 1"1/2 |                                      | M1          | M2-M3-M4-M5 |
|---|--------------------------------------|-------------|-------------|
|   |                                      |             |             |
|   |                                      |             |             |
| <b>PF331</b>                                  | Olio freni DOT3-4 - Brake oil DOT3-4 | Caterpillar |             |



I nostri ricambi non sono originali ma con essi perfettamente intercambiabili  
 Our spare parts are not original but with them perfectly interchangeable



**POMPE FRENO Ø 38,1 - 1"1/2**  
**MASTER CYLINDERS Ø 38,1 - 1"1/2**

**A  
01**

**POMPA FRENO - MASTER CYLINDERS** Ø 38,1 - 1"1/2

|                               |             |
|-------------------------------|-------------|
| <b>M1</b>                     | <b>M2</b>   |
| 14x1,5<br>M                   | 14x1,5<br>M |
| <b>M3</b>                     | <b>M4</b>   |
|                               |             |
| <b>Uscita Olio - Oil exit</b> |             |
|                               |             |

**PF401** Olio freni DOT3-4 - Brake oil DOT3-4

**POMPA FRENO - MASTER CYLINDERS** Ø 38,1 - 1"1/2

|                               |             |
|-------------------------------|-------------|
| <b>M1</b>                     | <b>M2</b>   |
| 22x1,5<br>M                   | 22x1,5<br>M |
| <b>M3</b>                     | <b>M4</b>   |
| 14x1,5<br>M                   | 14x1,5<br>M |
| <b>Uscita Olio - Oil exit</b> |             |
|                               |             |

**PF009** Olio freni DOT3-4 - Brake oil DOT3-4 **FIAT Allis**

**POMPA FRENO - MASTER CYLINDERS** Ø 38,1 - 1"1/2

|                               |           |
|-------------------------------|-----------|
| <b>M1</b>                     | <b>M2</b> |
| 12x1<br>M                     | 12x1<br>M |
| <b>M3</b>                     | <b>M4</b> |
|                               |           |
| <b>Uscita Olio - Oil exit</b> |           |
|                               |           |

**PF008** Olio freni DOT3-4 - Brake oil DOT3-4



I nostri ricambi non sono originali ma con essi perfettamente intercambiabili  
 Our spare parts are not original but with them perfectly interchangeable